



INSTRUCTION AND MAINTENANCE MANUAL: FPR SERIES PUMP (ORIGINAL INSTRUCTIONS)



DESCRIPTION

This manual contains installation, operation, assembly, disassembly and repair instructions for the Fristam FPR centrifugal pump.

The motors are standard NEMA totally enclosed fan cooled (TEFC) motors. They are C-face and have a locked front bearing. These motors do require feet. Replacements motors are easily available from local motor distributors.

SAFETY

This instruction and maintenance manual shall be read and completely understood prior to operation of the pump. The manual should be kept available at the pump installation location.

All applicable local/national regulation and laws shall be followed.

All work described herein may only be performed by qualified personnel.

Personal protective equipment (PPE) such as hearing protection may be required.

Despite inherent safe design measures some amount residual risk will remain. Throughout the manual these risks will be pointed out.

CAUTION

Begin all pump maintenance operations by disconnecting the energy source to the pump. Observe all lock out/tag out procedures as outlines by ANSI Z244.1-1982 and OSHA 1910.147 to prevent accidental start-up and injury.

TABLE OF CONTENTS

Safety2

Technical Information.....4

Installation.....6

Preventative Maintenance.....9

Seal Assembly Drawing10

Exploded Assembly—FPR 700-3540.....20

Seal Replacement—All Models (except 4001)26

Seal Replacement—FPR 400134

Pump Shaft Replacement.....38

Setting Impeller to Housing Gap.....40

FPR(S) Models Gapping Instructions41

Motor Replacement42

Warranty43

TECHNICAL INFORMATION

SPECIFICATIONS

| | |
|-----------------------------|----------------|
| Maximum Inlet Pressure..... | 150 PSI |
| Temperature Range | -40°F – 400°F |
| Noise Level..... | 60 – 85 dB (A) |

STANDARD MATERIALS OF CONSTRUCTION (NOTE: OTHER OPTIONS AVAILABLE)

| | |
|-------------------------------------|---|
| Product Contact Components..... | AISI 316L Stainless Steel |
| Seal Components: | |
| Rotating Seal | Chrome Oxide coated 316L Stainless Steel |
| Stationary Seal | Carbon |
| Flush Seal (if installed) | Ceramic |
| Product Contact Surface Finish..... | 32 in Ra |
| Flange Support | Cast Iron |
| Gaskets / O-rings | Viton |
| Cover O-ring | Buna |
| Motor | NEMA TEFC C-face (Painted Rolled Steel or Painted Cast Iron |
| | 3 Phase, 60 Hz, 208-230/460 VAC, 1750/3500 RPM |

FRONT PULL-OUT SEAL OPTIONS

| | |
|--|----------------------|
| Single Internal Mechanical | |
| Single Internal Mechanical with Double External Mechanical | |
| Recommended Seal Flush Pressure..... | 5 PSI Maximum |
| Recommended Seal Flush Flow..... | 1–2 Gallons per Hour |

SEAL SIZES

| | |
|--------------------|--|
| 757/857 | Used on Models: 700, 710, 720, 3520, 731, 3530, 740, 1740 & 3540 |
| Motor Frame Range: | 140TC – 320TC, Single Flange |
| 758/858 | Used on Models: 3450, 3550, 3640, 1051, 1161, & 3001 |
| Motor Frame Range: | 180TC–360TC, Double Flange |
| 102/859 | Used on Model 4001 |
| 890 | Used on Models 3552, 3642, & 3652 |
| Motor Frame Range: | 400 TSC–440TSC, Double Flange |

RECOMMENDED TORQUE VALUES

| | |
|--|------------|
| Impeller Nut: Models 700–3650, 3001..... | 40 ft-lbs |
| Impeller Nut: Models 1051, 1161, 4001..... | 90 ft-lbs |
| Impeller Nut: 890 Seal | 90 ft-lbs |
| Cover Nut: Model 4001..... | 105 ft-lbs |
| 757 Housing Clamp Bolt..... | 55 ft-lbs |
| 758 Housing Bolts | 50 ft-lbs |
| 102/859/890 Housing Bolts..... | 110 ft-lbs |
| 890 Seal Housing Bolts | 10 ft-lbs |

| <i>Motor Size</i> | <i>Motor Bolts</i> | <i>Shaft Collar Screws</i> |
|-------------------|--------------------|----------------------------|
| 56C – 140TC | 20 ft-lbs | 12 ft-lbs |
| 180TC – 280TSC | 55 ft-lbs | 24 ft-lbs |
| 280TC – 400TSC | 110 ft-lbs | 43 ft-lbs/105 ft-lbs* |
| 400TC – 440TSC | 110 ft-lbs | 105 ft-lbs |

**Model 4001 with 360TC motor: 105 ft-lbs shaft collar torque*

SHAFT RUN-OUT TOLERANCE

All models0.05 mm (0.002")

IMPELLER GAPS (TO HOUSING/TO COVER)

700, 710, 720, 731, 740, 1740.....0.5 mm (0.020") / 0.5 mm (0.020")
 3530, 3450, 3550, 3540, 3642, 3652, 1051.....1 mm (0.040") / 0.5 mm (0.020")
 35200.5 mm (0.020") / 1 mm (0.040")
 7501 mm (0.040") / 1 mm (0.040")
 1161, 3001.....1.5 mm (0.060") / 1.5 mm (0.060")
 40011.75 mm (0.070") / 2.25 mm (0.090")
 FPR(S)10 mm (0.400")/ 0.5 mm (0.020")

TOOLS FOR ASSEMBLY & DISASSEMBLY

9/16" socket 56C – 140TC motor bolts
 3/4" socket180TC – 280TC motor bolts, double flange housing bolts
 Single flange housing clamp bolt
 15/16" socket Impeller nut, 320TC – 360TC motor bolts
 24mm socket Cover nut, models 4001/1161
 32mm socket Impeller nut, models 4001/1161/3001
 3/16" Allen wrench socket.....56C – 180TC shaft collars
 1/4" Allen wrench socket..... 210TC – 250TC shaft collars
 5/16" Allen wrench socket..... 280TC – 360TSC shaft collars
 3/4" wrench.....Single flange clamp bolt
 RatchetFor loosening bolts
 Torque wrench.....For proper tightening
 Adjustable pliersFor removing water pipes
 Soft-faced hammerFor removing cover star nuts
 3/8" diameter rod.....For holding the shaft when tightening & loosening the impeller
 Food grade lubricant.....For lubricating o-rings and gaskets

INSTALLATION

UNPACKING

Check the contents and all wrapping when unpacking the pump. Inspect the pump carefully for any damage that may have occurred during shipping. Immediately report any damage to the carrier. Remove the shaft guard and rotate the pump shaft by hand to make sure the impeller rotates freely. Keep the protective caps over the pump inlet and outlet in place until you are ready to install the pump.

INSTALLING

Prior to actually installing the pump, ensure that:

- The pump will be readily accessible for maintenance, inspection and cleaning.
- Adequate ventilation is provided for motor cooling.
- The drive and motor type is suitable for the environment where it is to be operated. Pumps intended for use in hazardous environments (i.e. explosive, corrosive, etc.) must use a motor and drive with the appropriate enclosure characteristics. Failure to use an appropriate motor type may result in serious damage and/or injury.

PIPING GUIDELINES

This section describes good piping practices to obtain maximum efficiency and service life from your pump.

Maximum performance and trouble-free operation require adherence to good piping practices.

- Ensuring proper piping support and alignment at both the suction inlet and discharge outlet can help prevent serious damage to the pump housing (Figure 23).
- Avoid abrupt transitions in the piping system (Figure 24).
- Avoid throttling valves in the suction piping.
- Keep suction lines as short and direct as possible.
- Ensure that the NPSH available in the system is greater than NPSH required by the pump.
- Avoid sump areas where sediments may collect (Figure 25).

Figure 23

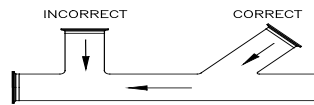
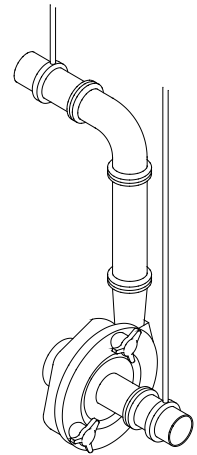

Figure 24

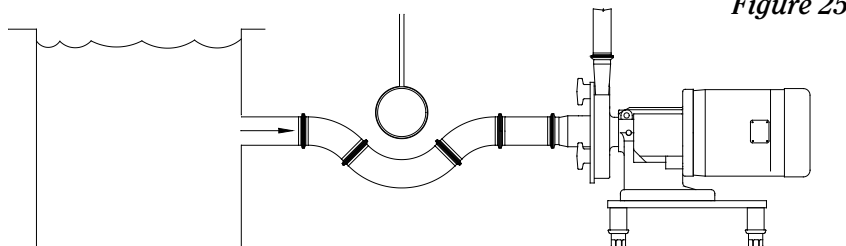

Figure 25

- Avoid the formation of air pockets in the piping (Figure 26).
- Avoid abrupt closure of shut-off valves, this may cause hydraulic shock which can cause severe damage to the pump and system.

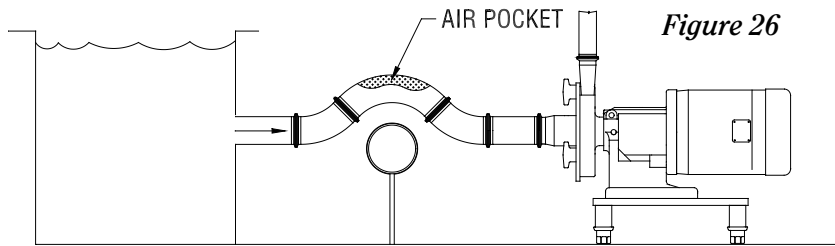

Figure 26

- Avoid elbows in the suction line if possible. When necessary they should be located 5 pipe diameters away from the pump inlet, and have a bend radius greater than 2 pipe diameters (Figure 27).
- Check valves in discharge line should be a minimum of 5 ft. away from the pump outlet (Figure 27).

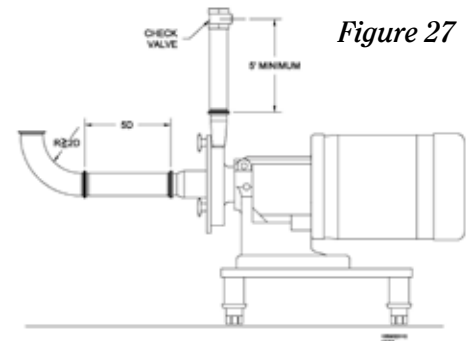

Figure 27

ELECTRICAL INSTALLATION

We use standard duty TEFC motors unless otherwise specified. Many motor options are available: washdown, flameproof, explosion proof, hostile duty or chemical duty.

The motor selected should meet the requirements of the specified operating conditions. A change in conditions (for example, higher viscosity, higher specific gravity, lower head losses) can overload the motor. When changing operating conditions or whenever there is any doubt, please contact Fristam Pumps, Inc., for technical assistance.

Have an electrician connect the motor using sound electrical practices. Provide adequate protection. Pumps fitted with mechanical seals must not run dry, not even momentarily. Determine the direction of rotation by watching the motor fan, which must turn clockwise.

PUMP OPERATIONS

START-UP INSTRUCTIONS

- Remove any foreign matter that may have entered the pump.
- Do not use the pump to flush the system!
- Check pump for proper rotation as indicated on the pump. **Proper motor direction is clockwise when looking at the fan end of the motor.** (NOTE: When checking the direction of rotation, the pump must be full of liquid.)
- Never run the pump dry, even momentarily. Seal damage can result.

SHUT-DOWN INSTRUCTIONS

- Shut off the power supply to the pump.
- Close the shut-off valves in the suction and discharge piping.
- Drain and clean the pump.
- Protect the pump against dust, heat, moisture and impact damage.

INSTALLATION OF WATER FLUSH FOR DOUBLE MECHANICAL SEAL

Set up the water flush for the double mechanical seal as shown (Figure 28). Use only between 1-2 gallons per hour of water at a maximum pressure of 5 PSI. Excessive flow of water through the seal increases the pressure inside the seal. Note: maximum pressure inside the seal is 5 PSI. Excessive flow/pressure through the seal flush will cause excessive wear and shorten seal life.

Pipe the exit side of the water flush with 2-5 feet physical height of tubing. This ensures that some water is always in the center seal and the seal never runs dry.

It is possible to inject steam through the center seal (within the pressure requirements). We do not recommend using steam alone for the cooling/lubricating of the seal.

It is desirable to have the flush water on the outlet side visible. This allows an easy check to see that the flush water is on and also if the seal is functioning properly. In a malfunctioning seal the flush water will disappear, become discolored, or show an unusual increase in flow. If these conditions exist, check the seal and replace if necessary.

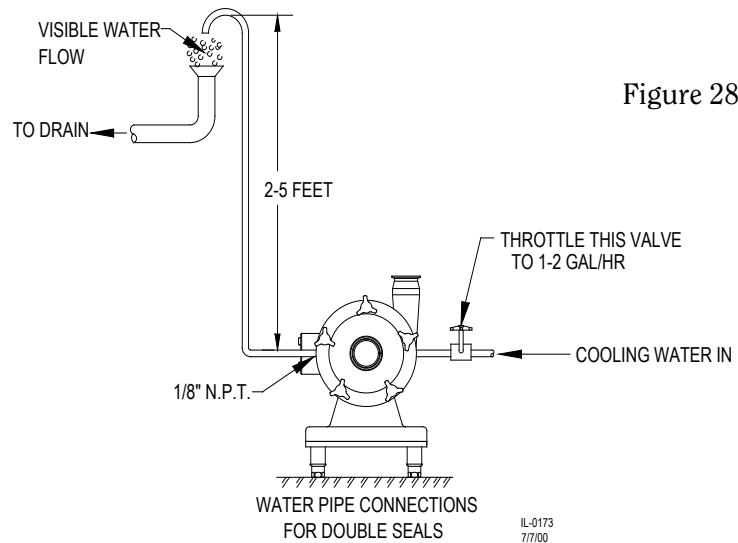

Figure 28

RECOMMENDED PREVENTIVE MAINTENANCE

RECOMMENDED SEAL MAINTENANCE

Visually inspect mechanical seal daily for leakage. Replace mechanical seal annually under normal duty. Replace mechanical seal as often as required under heavy duty.

ELASTOMER INSPECTION

Inspect all elastomers when performing pump maintenance. We recommend replacing elastomers (o-rings and gaskets) during seal, pump shaft and/or motor replacement. If the impeller nut gasket fails, the threaded hole on the impeller nut and the threads on the end of the shaft will need to be cleaned. A wire brush is recommended for cleaning these threads.

PUMP SHAFT INSPECTION

Inspect the pump shaft and collar annually for wear. Inspect the shaft collar bolt(s) annually or more often in corrosive environments.

MOTOR LUBRICATION RECOMMENDATIONS

Use a high grade ball and roller bearing grease. (See Tables 1-3 for more details.) Please consult the motor manufacturers' recommendations for lubrication.

*Table 1: Motor Lubrication Intervals for Standard Conditions**

| Frame Size: NEMA (IEC) | 3500 RPM | 1750 RPM |
|---------------------------------|-----------------|-----------------|
| Up to 210 incl. (132 IEC) | 5,500 hrs. | 12,000 hrs. |
| Over 210 to 280 incl. (180 IEC) | 3,600 hrs. | 9,500 hrs. |
| Over 280 to 360 incl. (225 IEC) | 2,200 hrs. | 7,400 hrs. |

**For severe conditions, multiply interval hours by 0.5; for extreme conditions, multiply interval hours by 0.1*

Table 2: Service Conditions Definitions

| Service Conditions | Max. Ambient Temperature | Atmospheric Contamination |
|---------------------------|---------------------------------|---------------------------------------|
| Standard | 104°F (40°C) | Clean, little corrosion |
| Severe | 122°F (50°C) | Moderate dirt, corrosion |
| Extreme | >122°F (50°C) | Severe dirt, abrasive dust, corrosion |

Table 3: Volume of Grease to be Added per Bearing

| Frame Size NEMA (IEC) | Grease IN³ | Volume TSP |
|---------------------------------|------------------------------|-------------------|
| Up to 210 incl. (132 IEC) | 0.6 | 2.0 |
| Over 210 to 280 incl. (180 IEC) | 1.2 | 3.9 |
| Over 280 to 360 incl. (225 IEC) | 1.5 | 5.2 |

SINGLE SEAL ASSEMBLY (SIZES 757/758, WAVE SPRING)

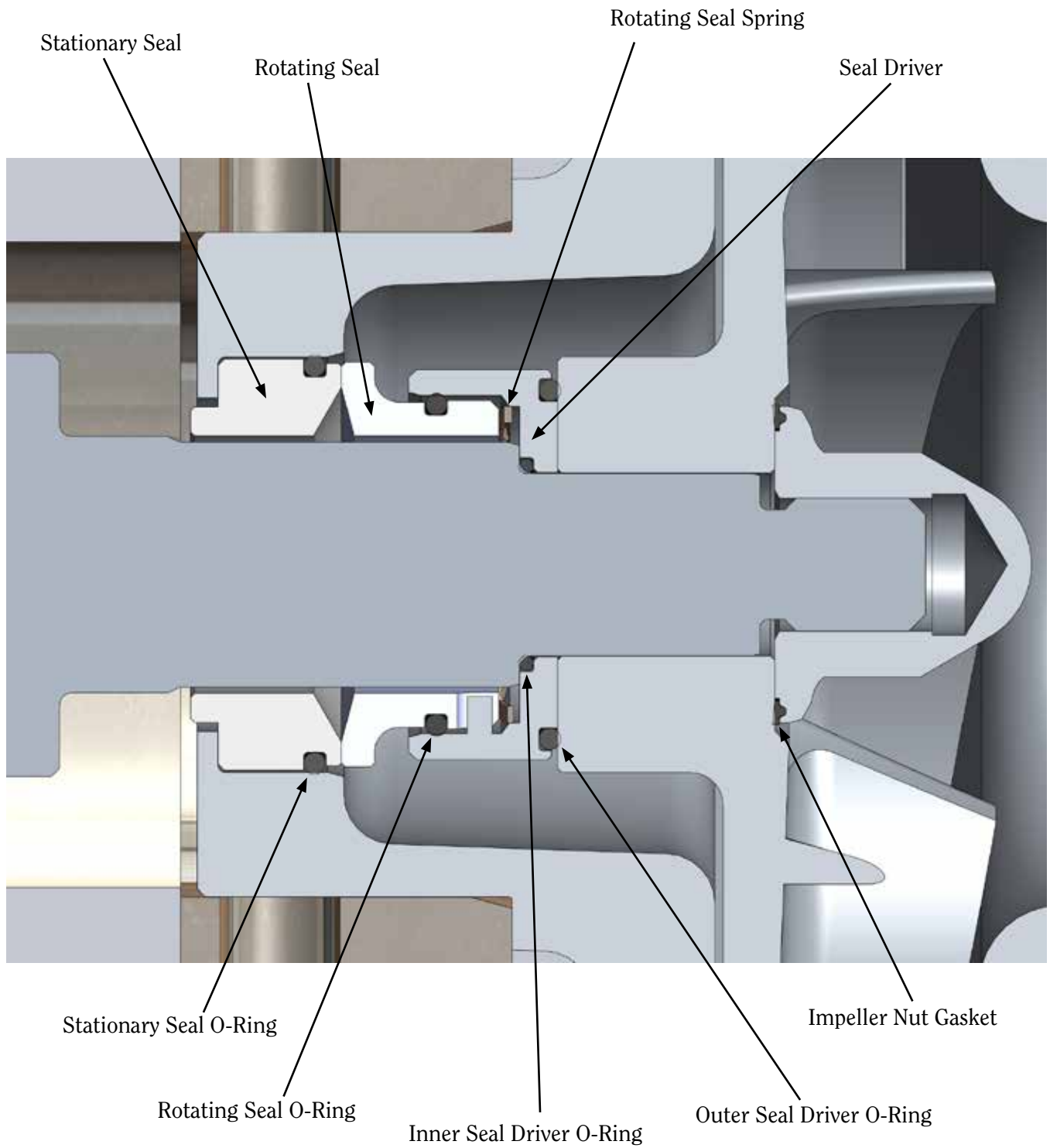

DOUBLE SEAL ASSEMBLY (SIZES 757/758, WAVE SPRING)

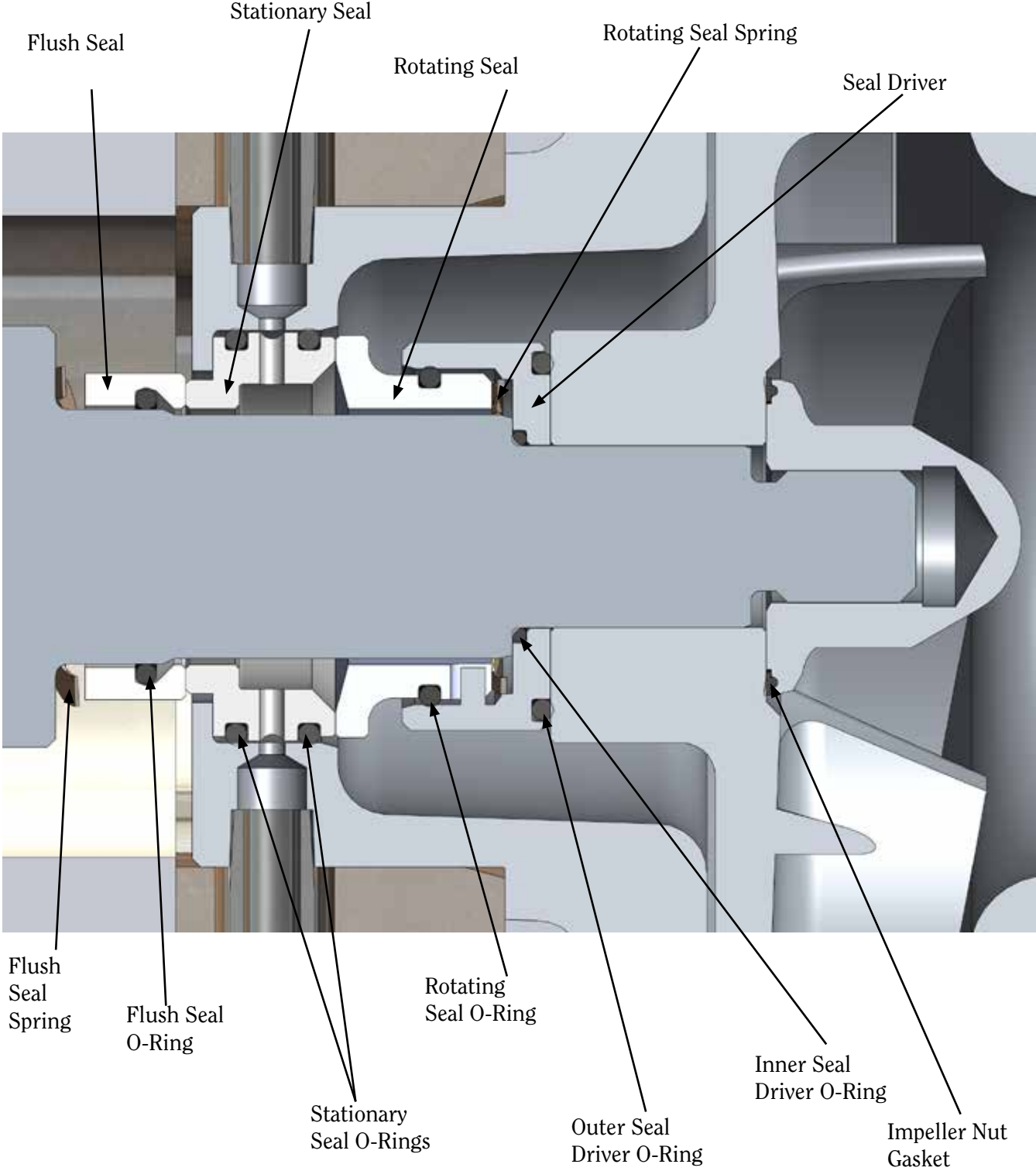

SINGLE SEAL ASSEMBLY (SIZES 857/858, COIL SPRING)

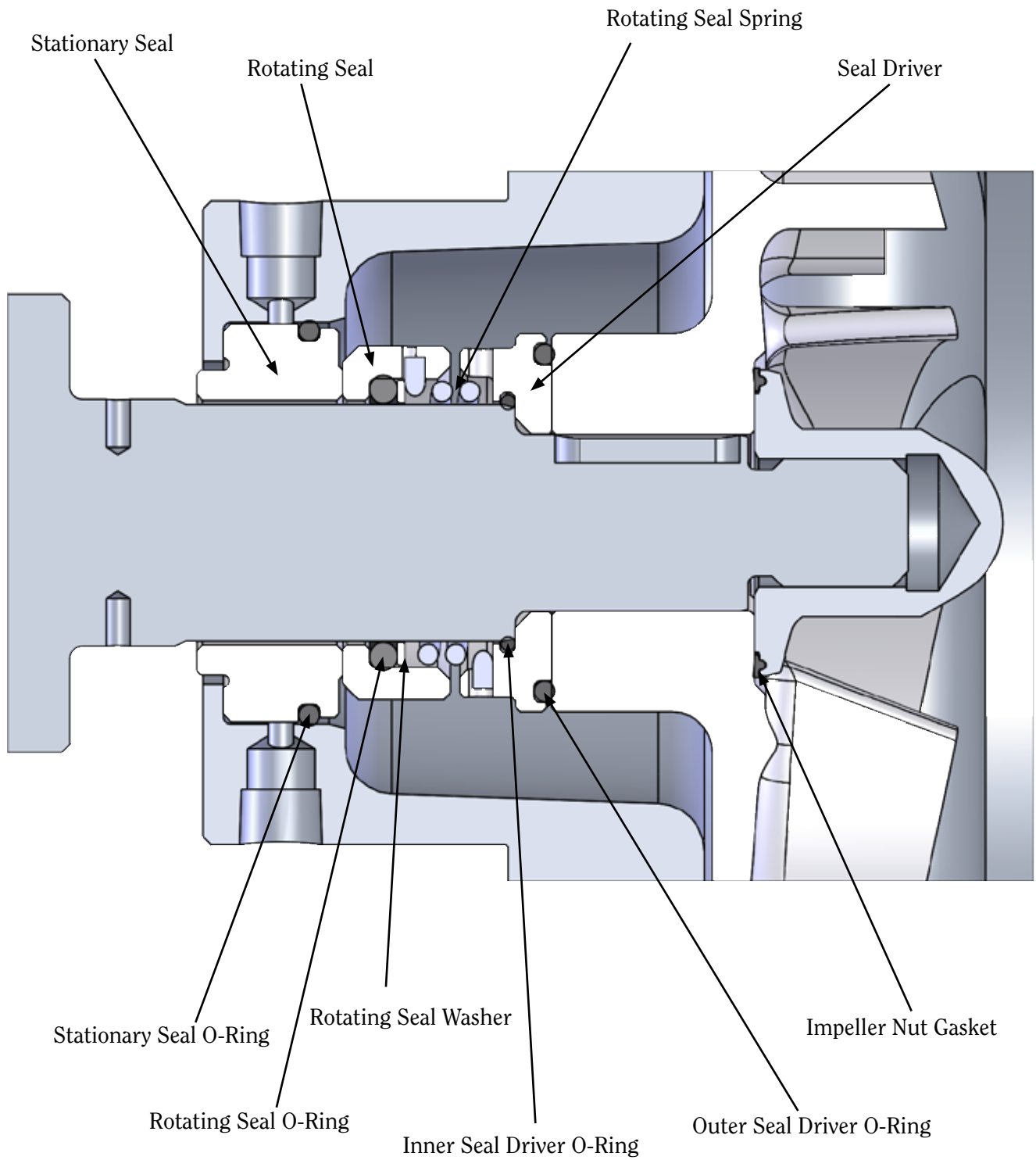

DOUBLE SEAL ASSEMBLY (SIZES 857/858, COIL SPRING)

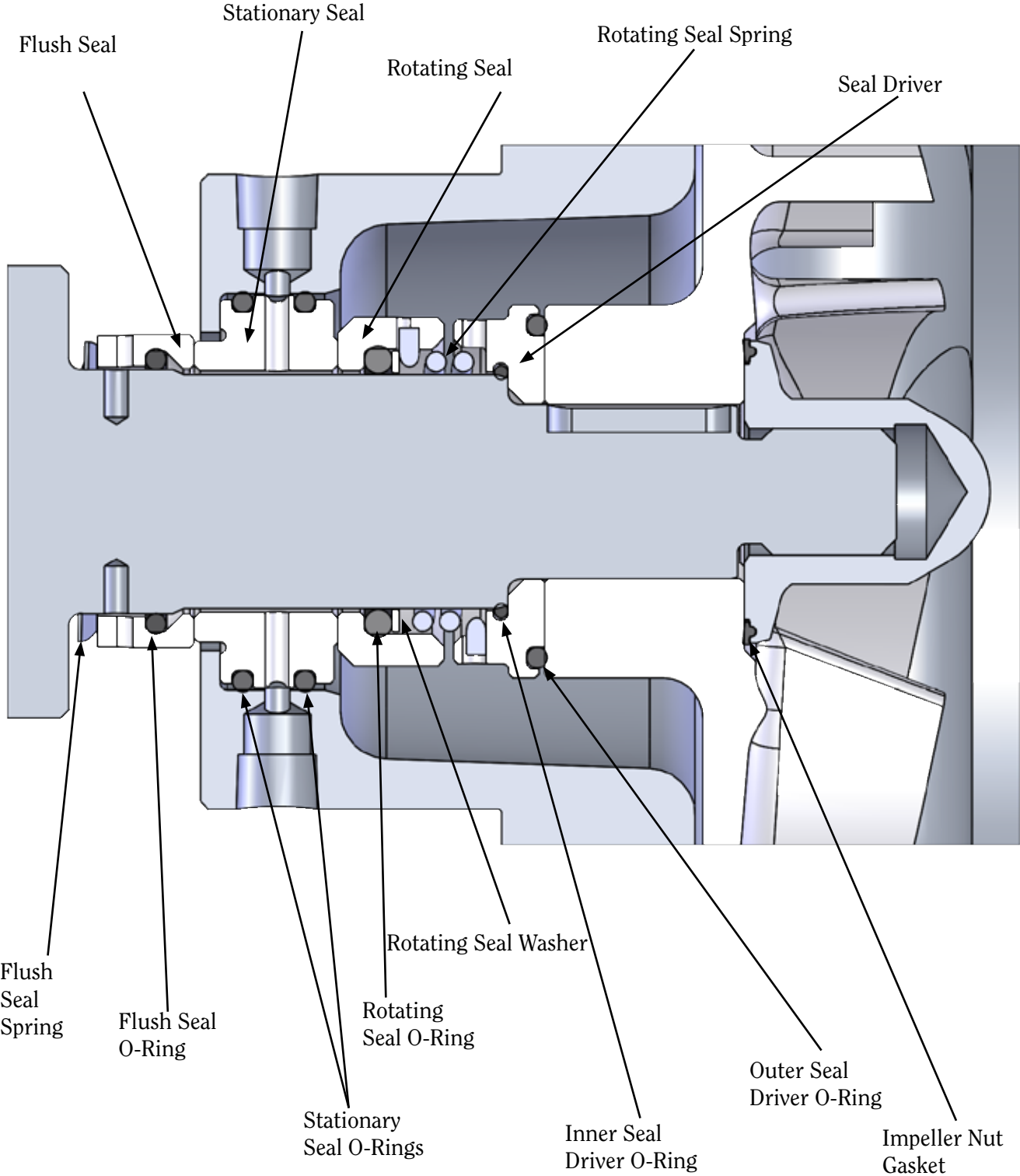

SINGLE SEAL ASSEMBLY (SIZE 859, COIL SPRING)

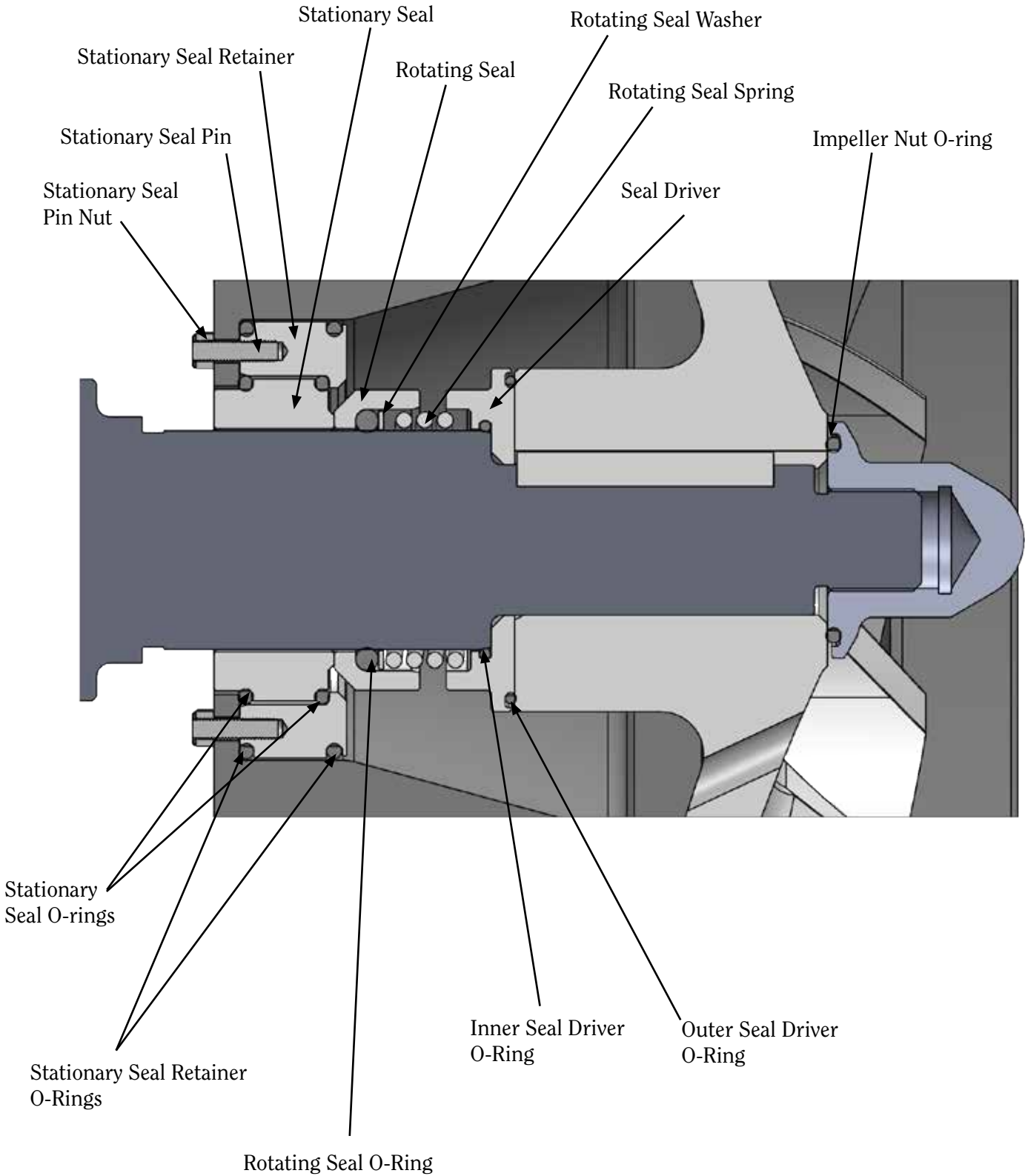

DOUBLE SEAL ASSEMBLY (SIZE 859, COIL SPRING)

Flush Seal

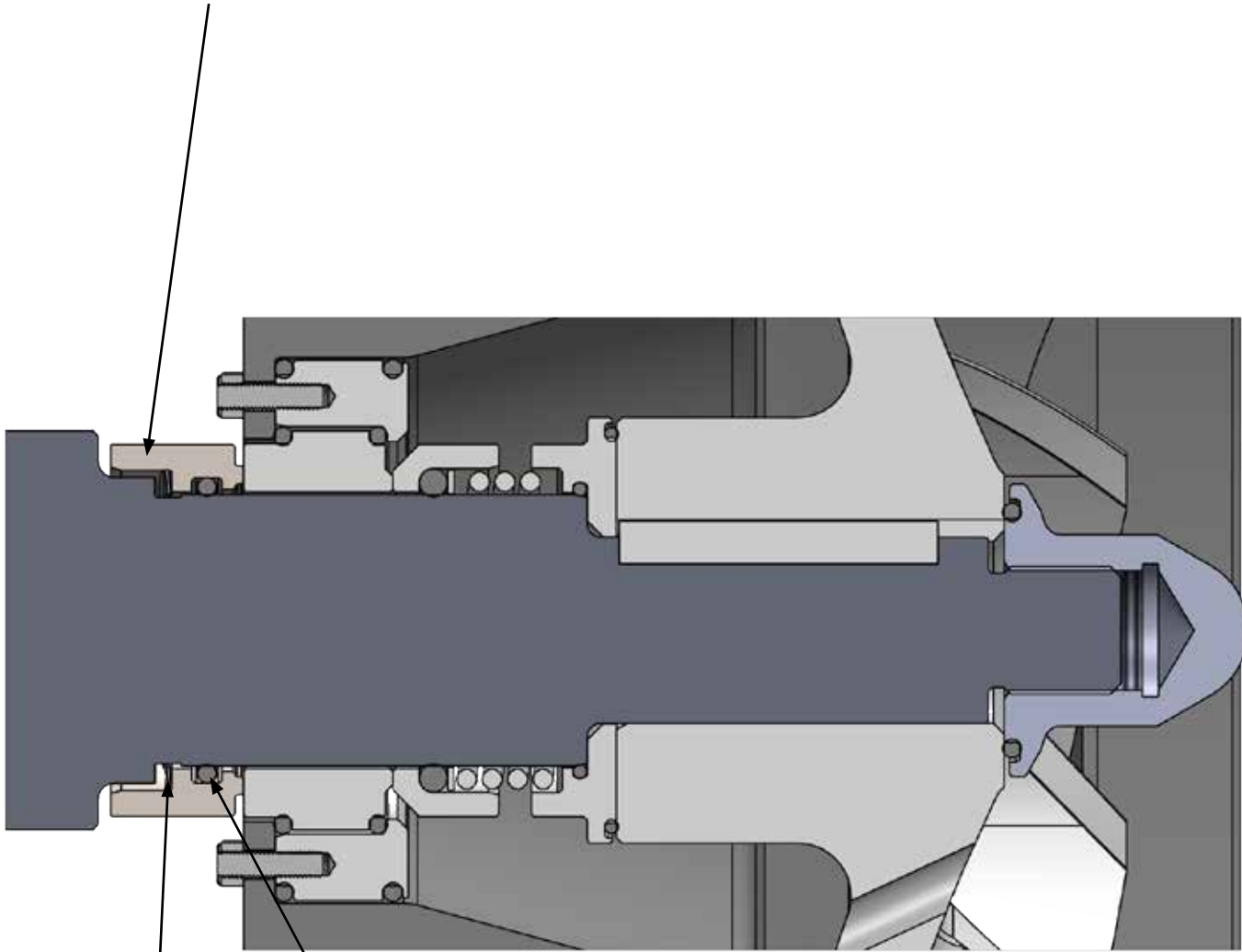

Flush Seal
O-Ring

Flush Seal
Spring

SINGLE SEAL ASSEMBLY (SIZE 890 / SIZE 758 ON MODEL 3640 ONLY)

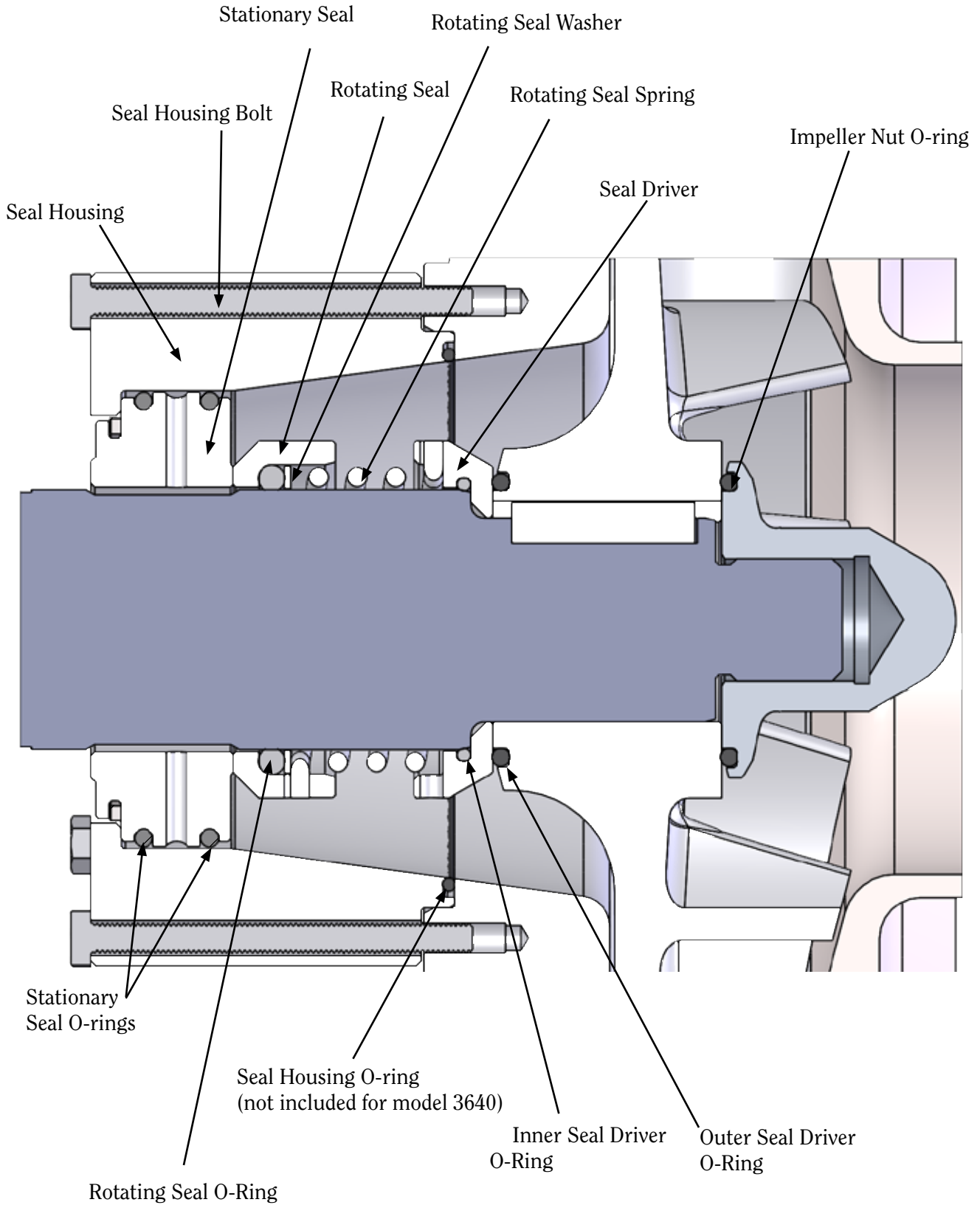

DOUBLE SEAL ASSEMBLY (SIZE 890 / SIZE 758 ON MODEL 3640 ONLY)

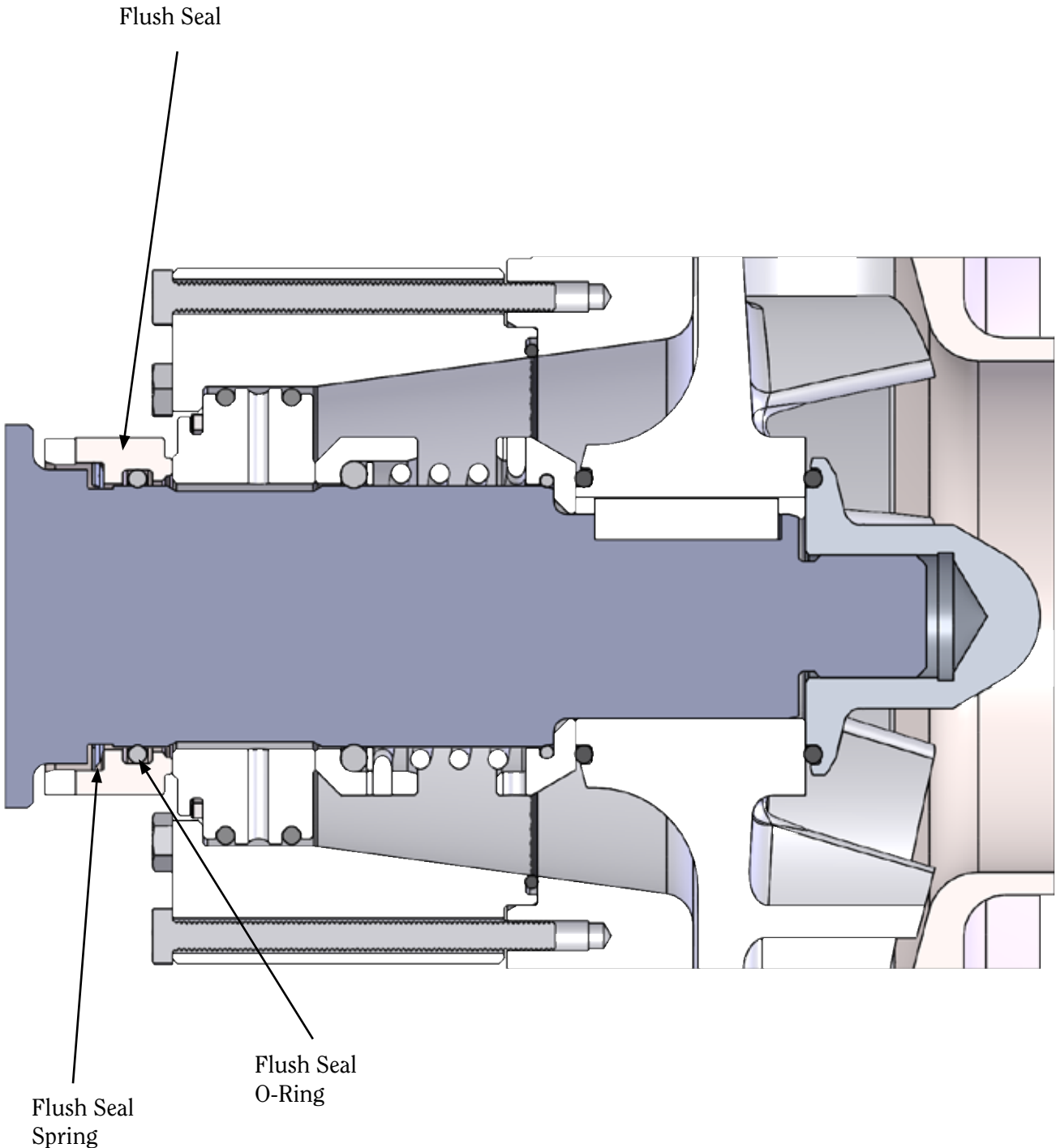

SINGLE SEAL ASSEMBLY (SIZE 102)

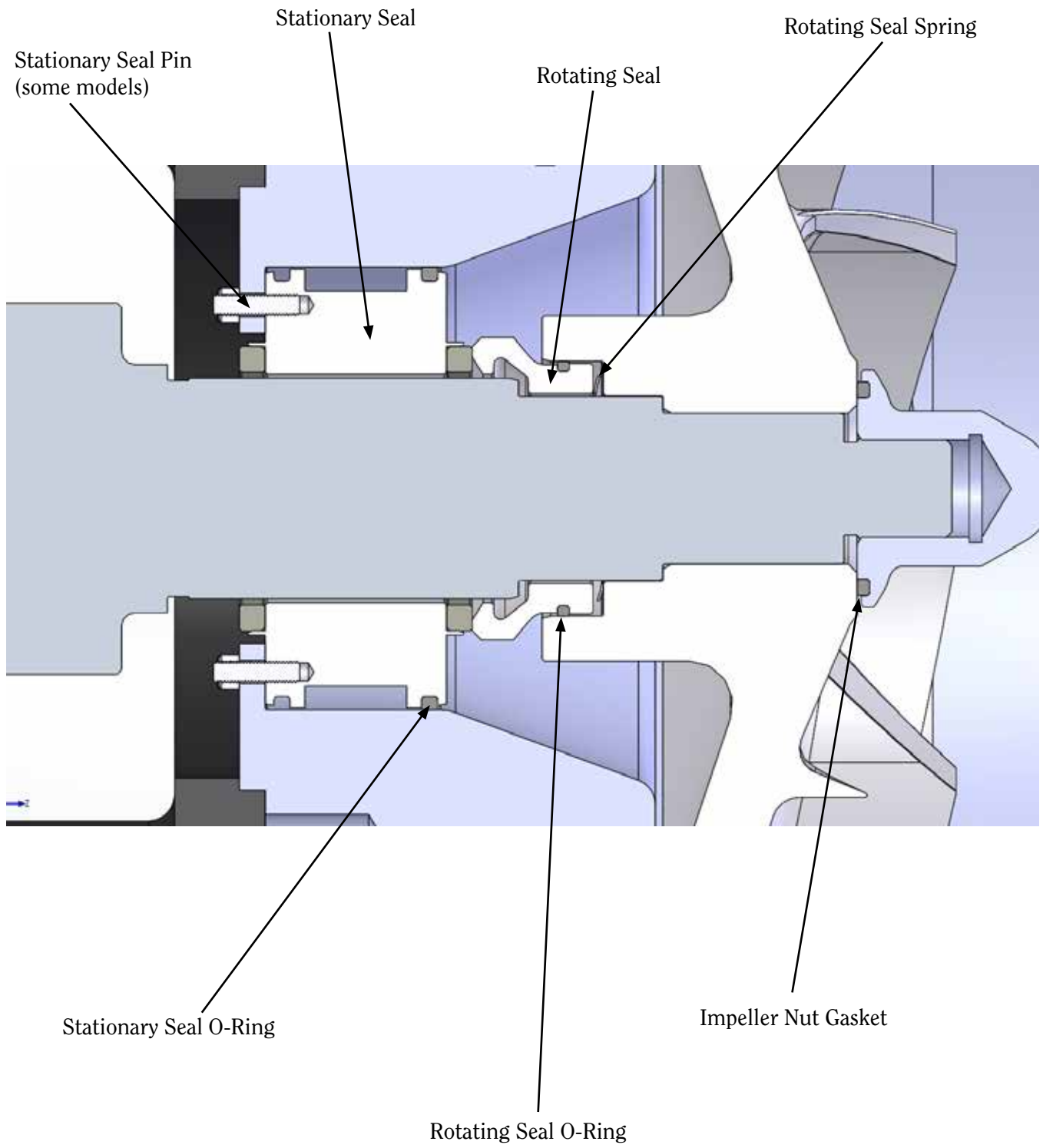

DOUBLE SEAL ASSEMBLY (SIZE 102)

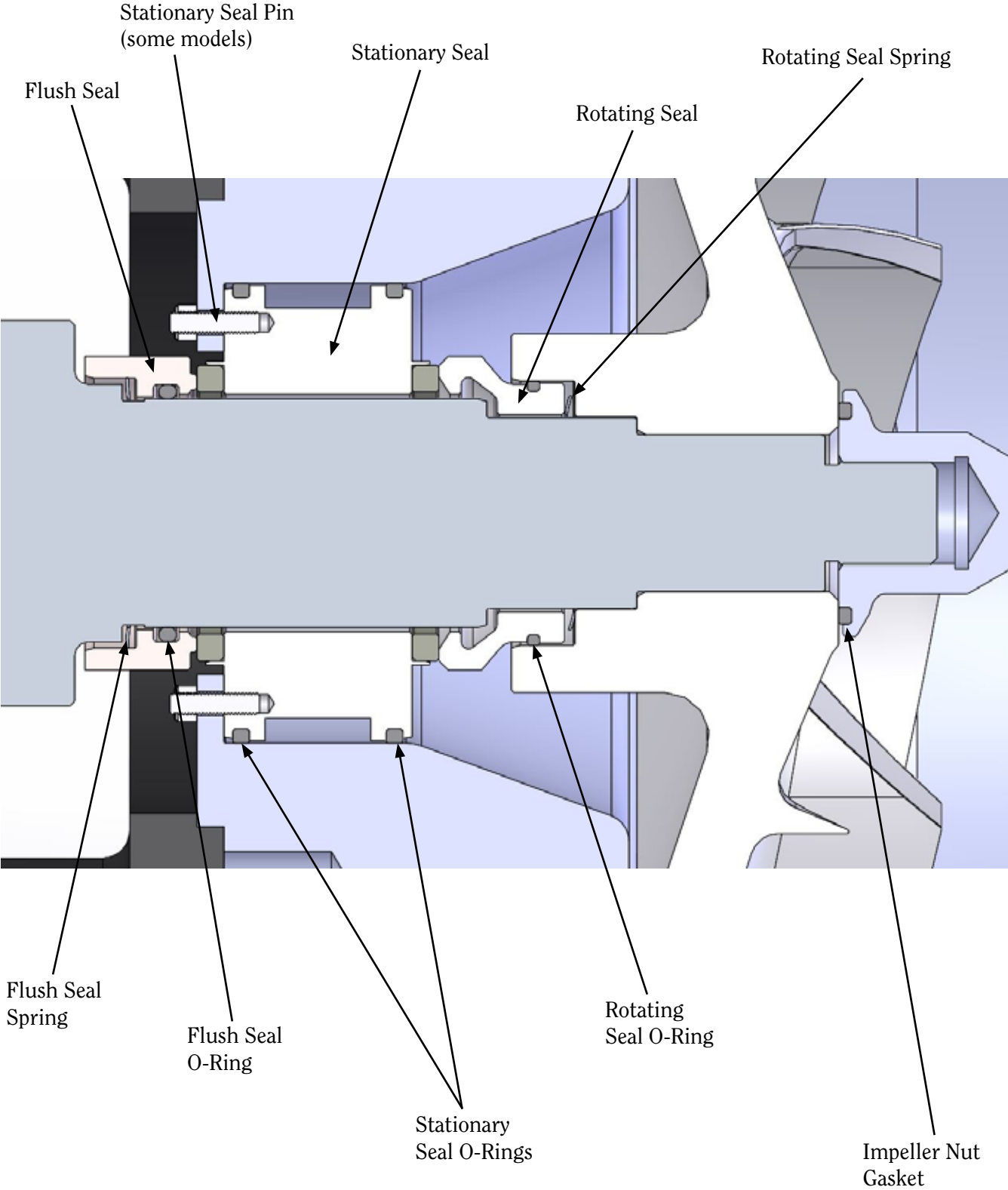

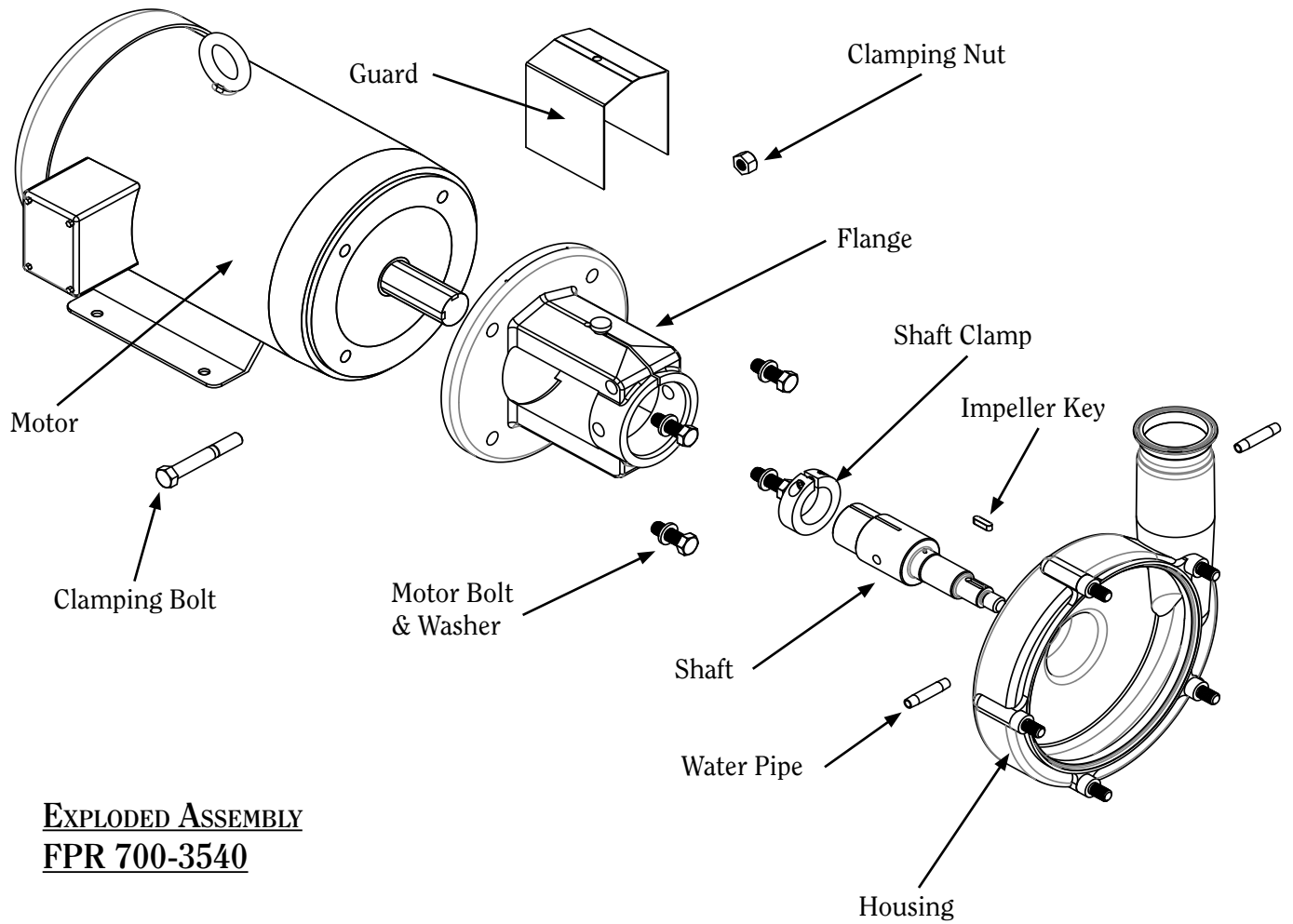

EXPLODED ASSEMBLY
FPR 700-3540

Coil spring option 857

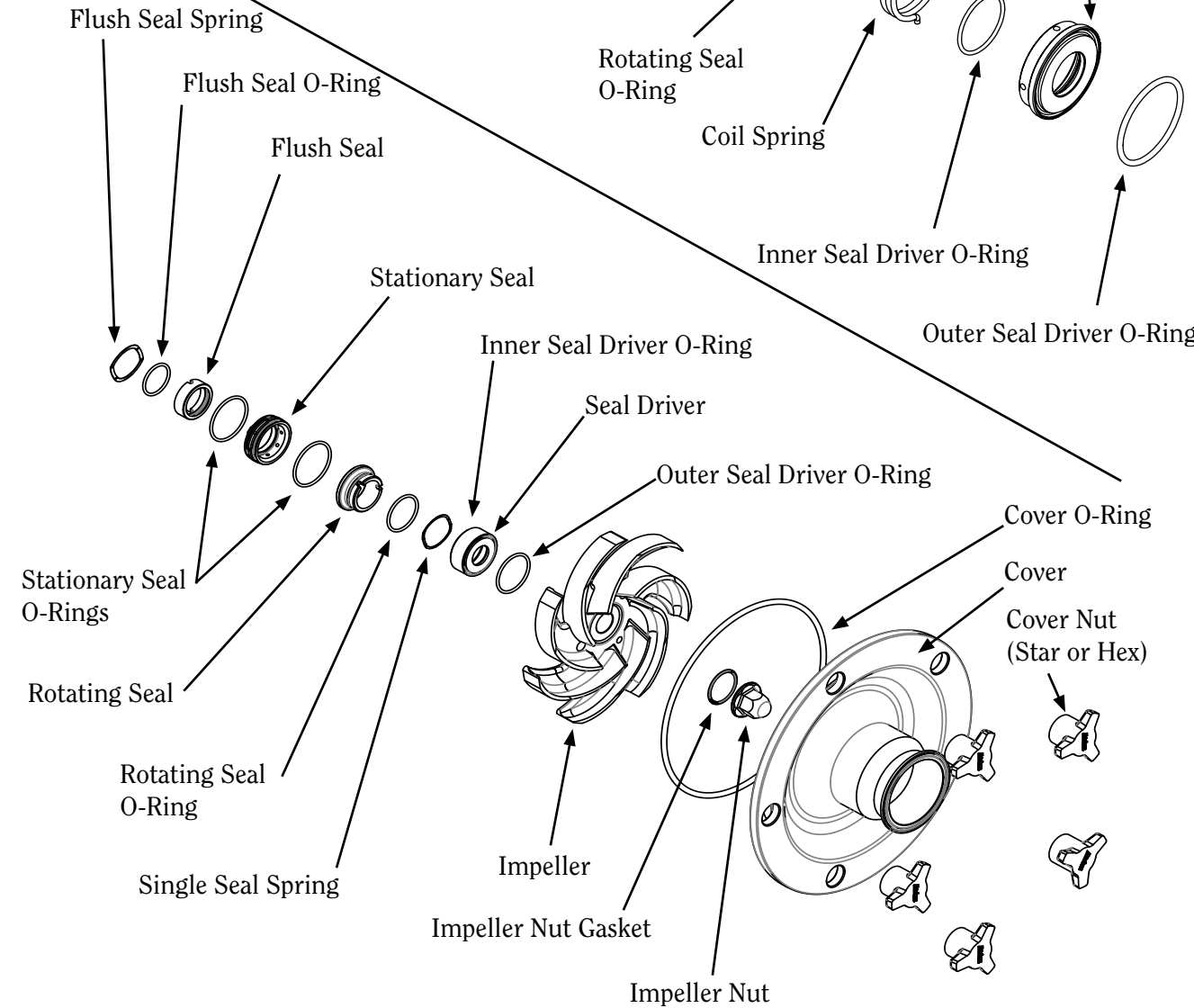
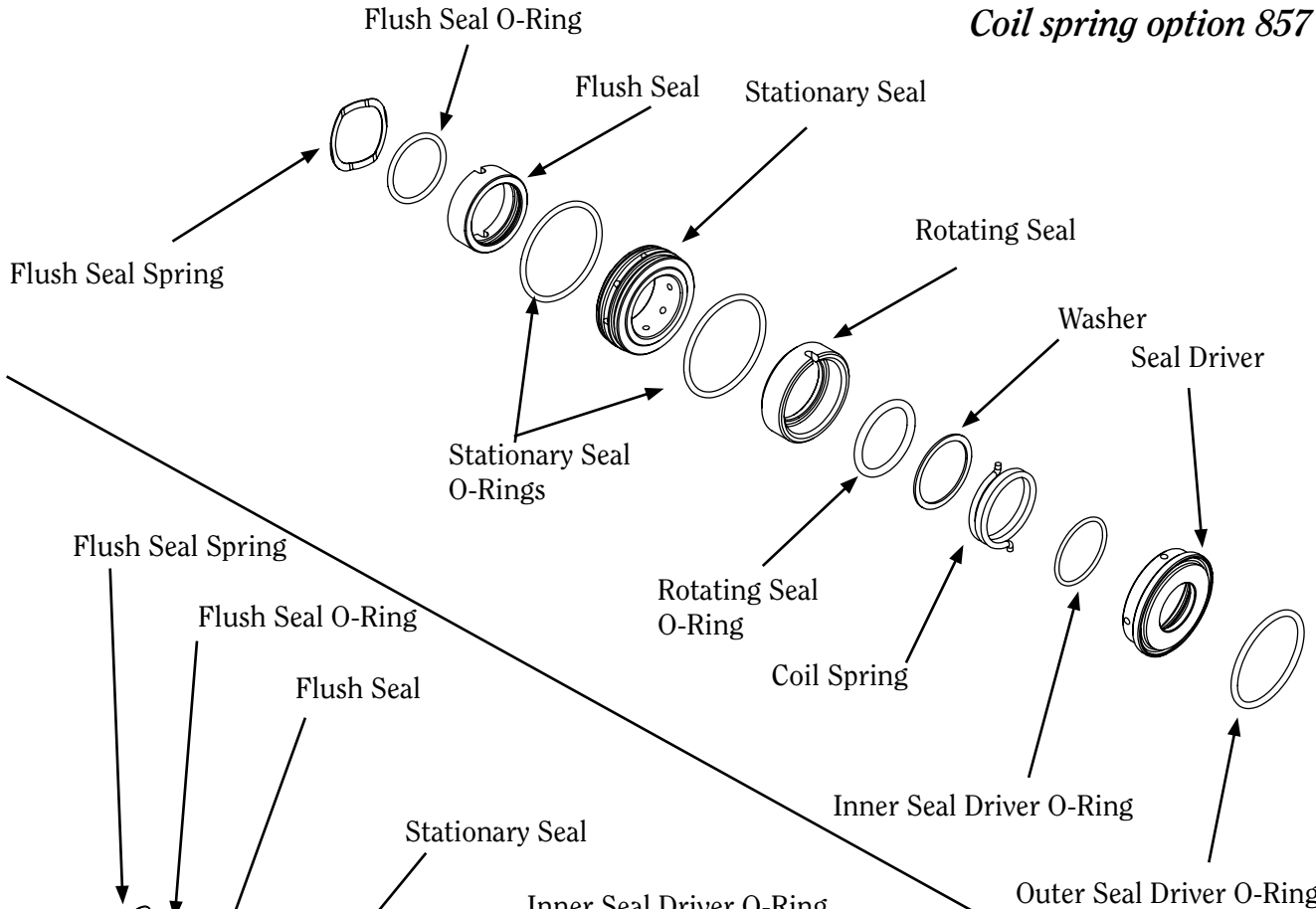

Wave spring option 757

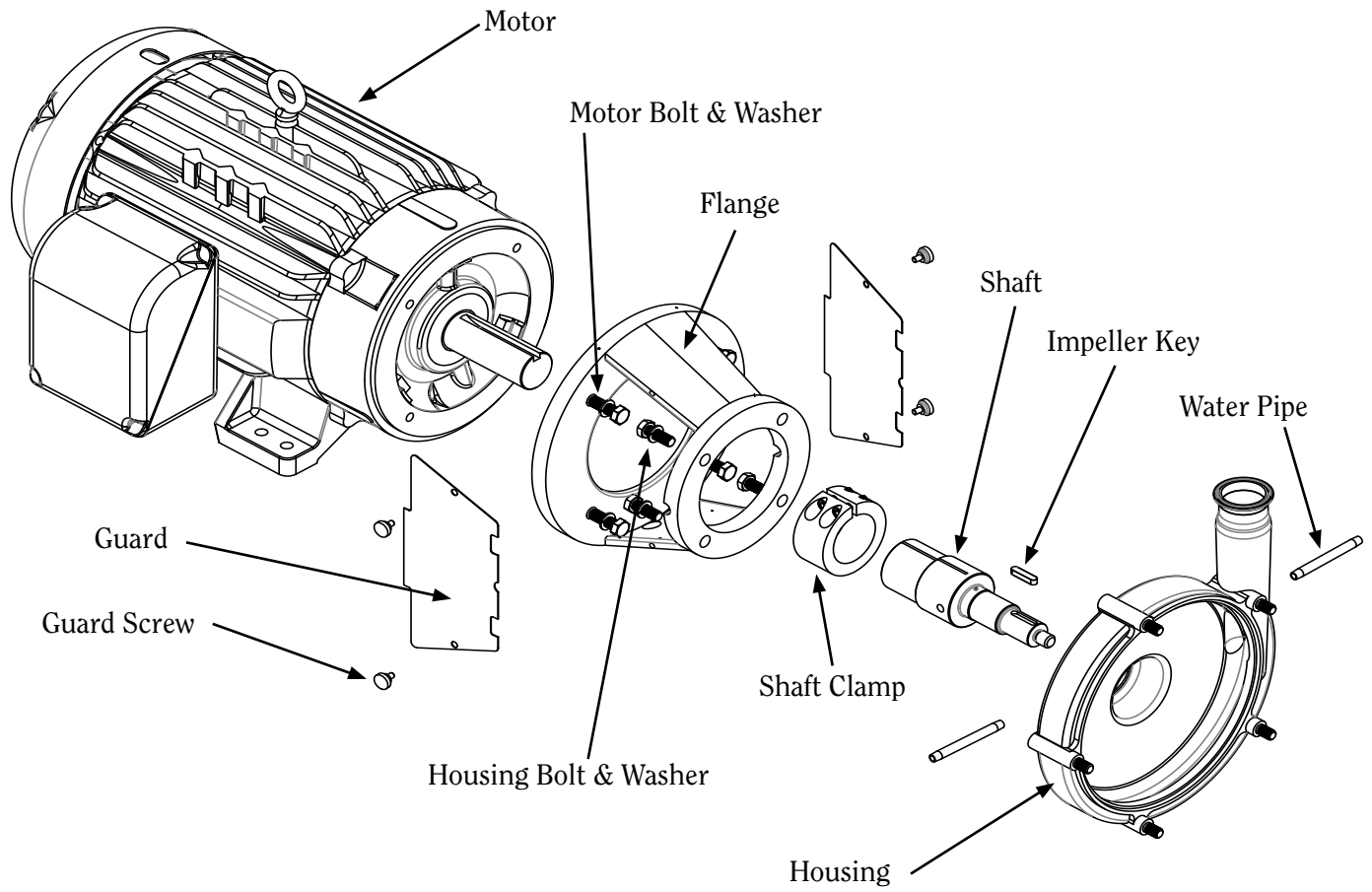

EXPLODED ASSEMBLY
FPR 3450, 3550, 3640, 1051, 1161, & 3001

Coil spring option
857/858/890

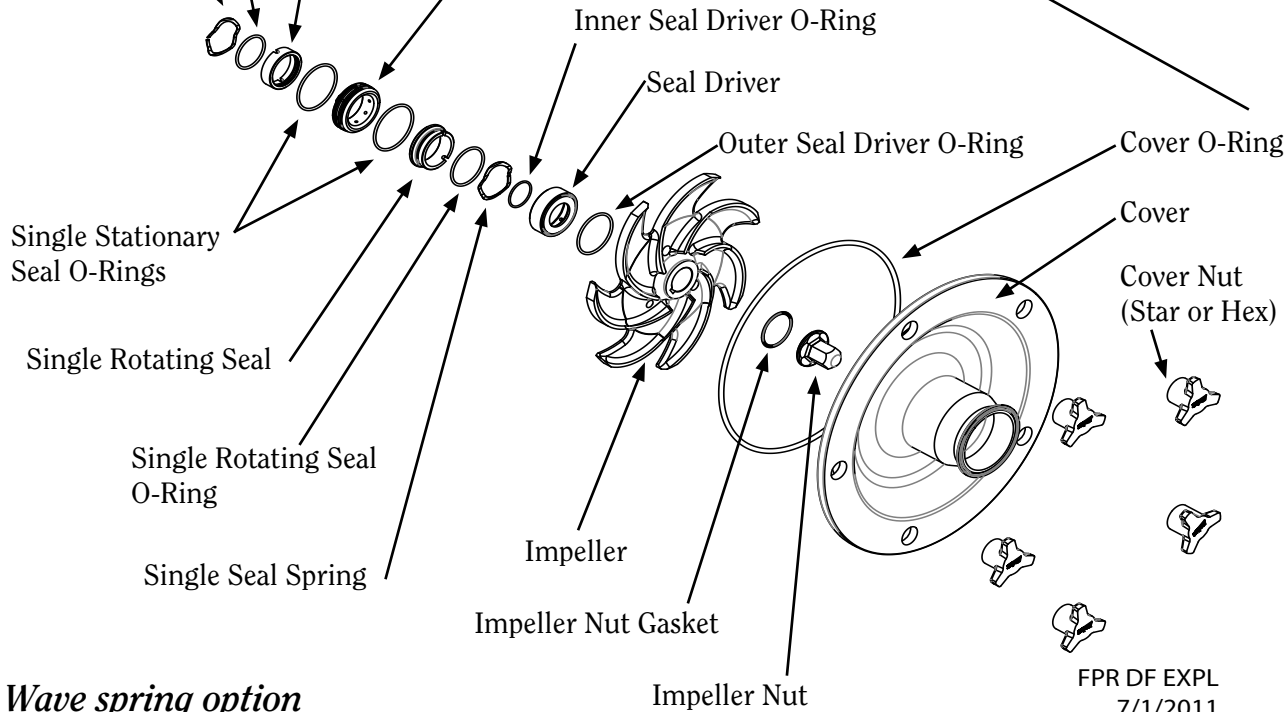
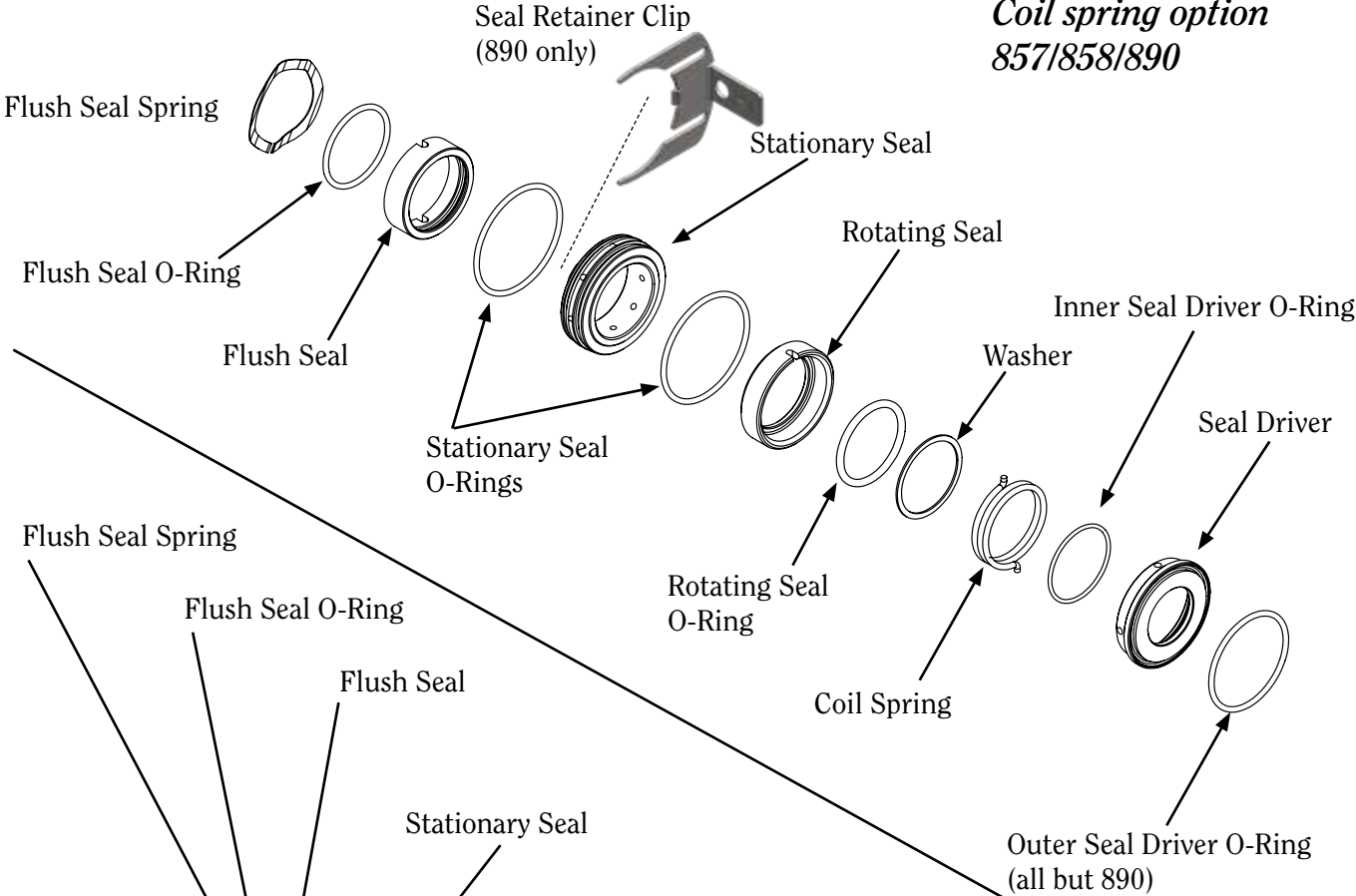

Wave spring option
757/758

EXPLODED ASSEMBLY
FPR 4001

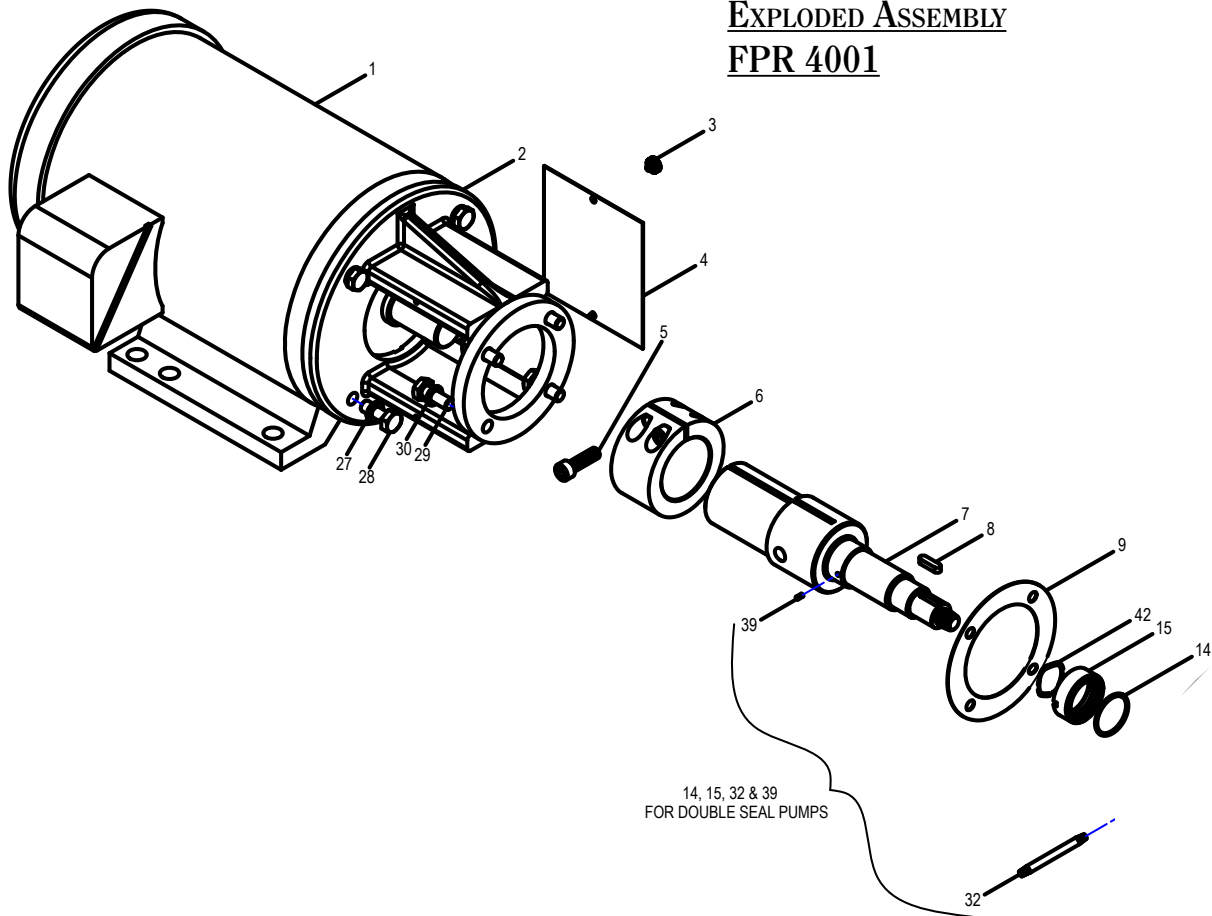

- | | | | |
|-----|-----------------------------|-----|-------------------------|
| 1. | Motor | 23. | Impeller Nut |
| 2. | Flange Support | 24. | Pump Cover |
| 3. | Guard Nuts | 25. | Impeller Nut Gasket |
| 4. | Shaft Guards | 26. | Cover Nuts |
| 5. | Shaft Collar Screw | 27. | Motor Lock Washer |
| 6. | Shaft Collar | 28. | Motor Bolts |
| 7. | Shaft | 29. | Housing Bolts |
| 8. | Impeller key | 30. | Housing Lock Washer |
| 9. | Shim (for some frame sizes) | 32. | Water Piping (optional) |
| 10. | Pump Housing | 33. | Front Rotating Seal |
| 14. | Double Seal O-ring | 34. | Single Seal Spring |
| 15. | Double Rotating Seal | 38. | Housing Stud |
| 18. | Stationary Seal O-ring | 39. | Shaft Pin |
| 19. | Stationary Seal | 40. | Impeller Pin |
| 21. | Cover Gasket | 41. | Rotating Seal O-ring |
| 22. | Impeller | 42. | Double Seal Spring |

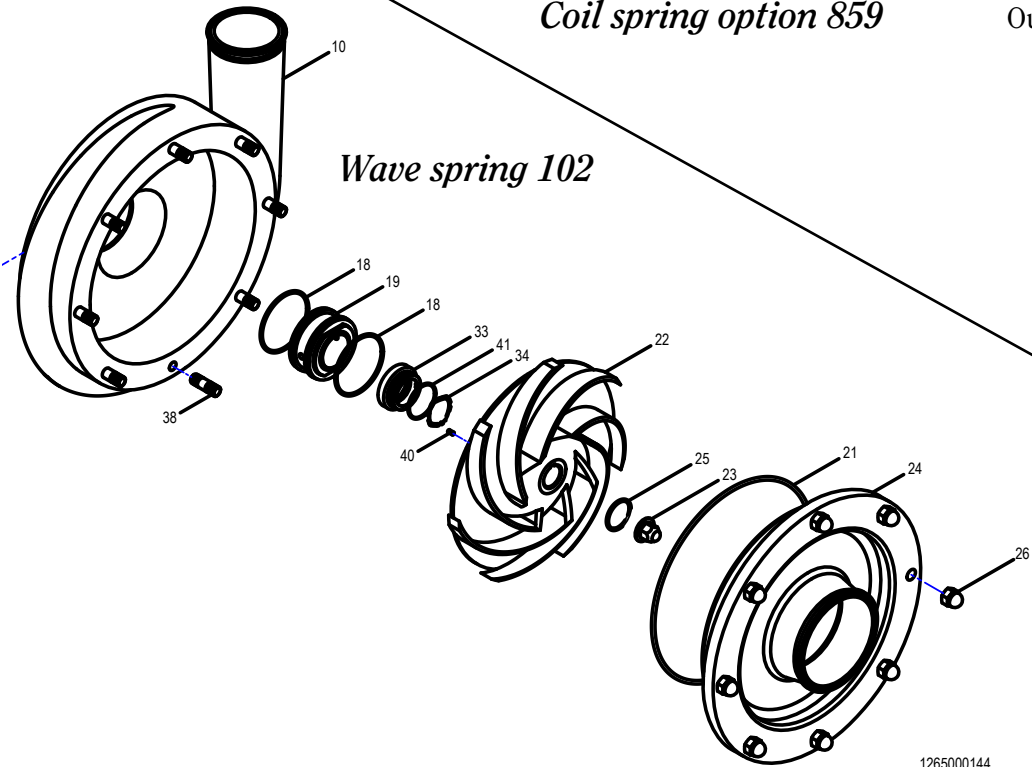
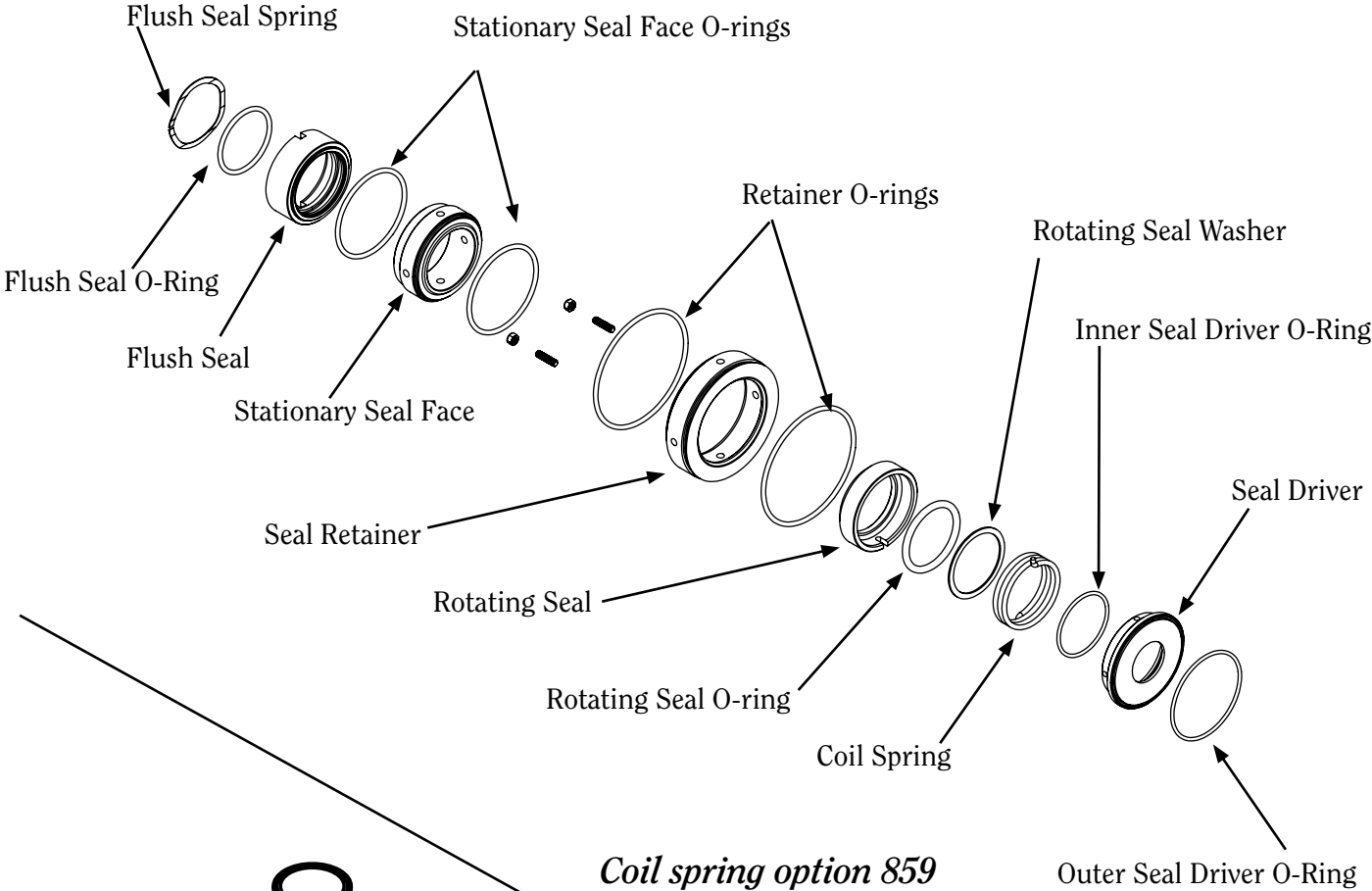

SEAL REPLACEMENT

DISASSEMBLY (ALL MODELS EXCEPT 4001)

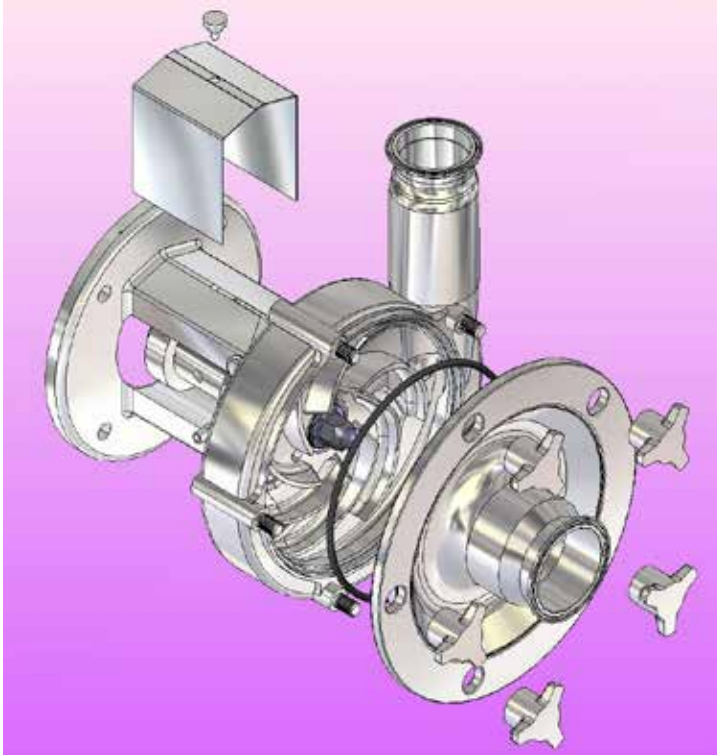

Note: When replacing ANY seal part, it is important that ALL seal wear parts are replaced to ensure seal integrity.



<https://youtu.be/je4Sl9-OhHU?t=57>

Figure 1

Remove flange guard.

Remove cover star nuts with soft-faced hammer.

Remove cover and discard cover o-ring.



3/8" Shaft Hole

Figure 2

Place 3/8" rod or Phillips screwdriver in shaft hole. Use 15/16" socket with ratchet to remove impeller nut. Discard impeller nut gasket.

Remove impeller and discard impeller o-ring.

Remove key.

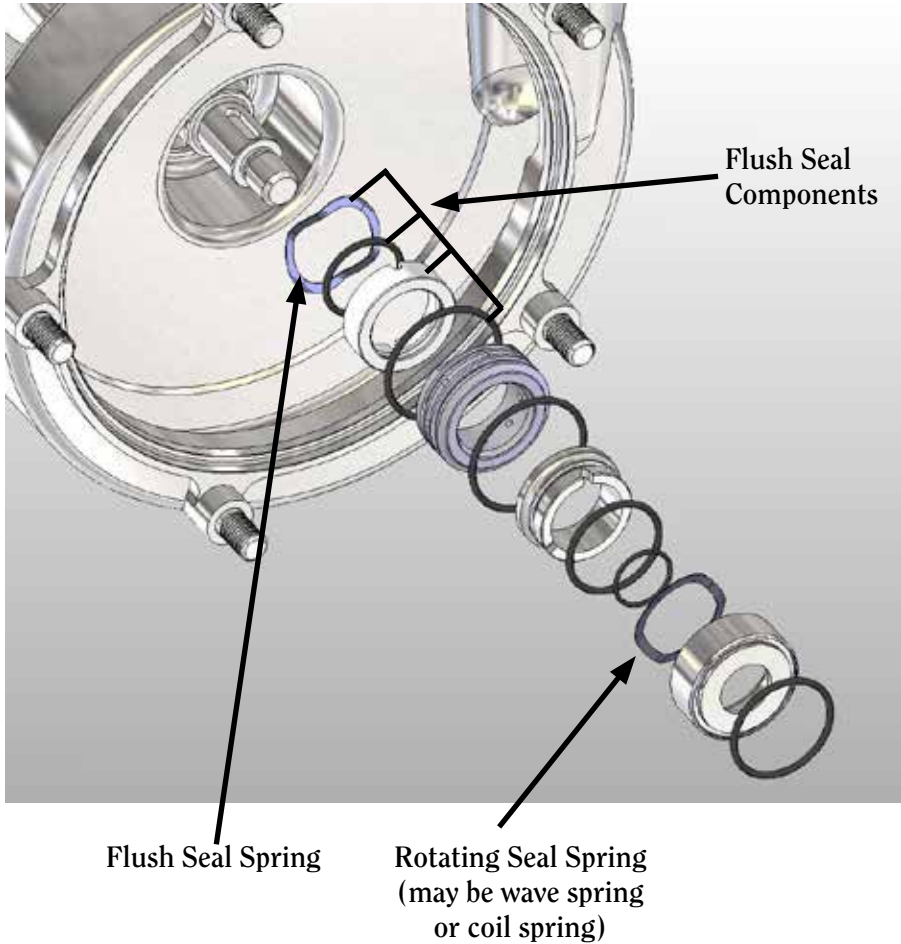
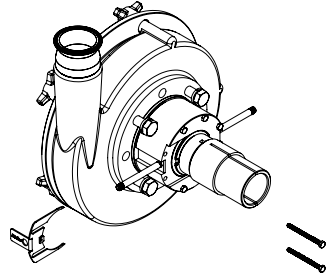

Figure 3

Remove seal driver/rotating seal assembly.

Discard rotating seal, o-rings and spring.

890 Seal Only: Remove seal retainer seal housing bolts. Remove seal retainer clip.



Remove stationary seal and discard.

Double Seal Only: Remove double rotating seal and double spring and discard. Seal pin nuts will need to be loosened first for the 859 seal.

(Note: to distinguish between the wave springs: FLUSH SEAL SPRING HAS A WHITE STRIPE ON THE OUTSIDE EDGE; ROTATING SEAL SPRING DOES NOT

890 Seal Only: Remove seal housing bolts. Remove seal housing. Remove and discard the seal housing o-ring.

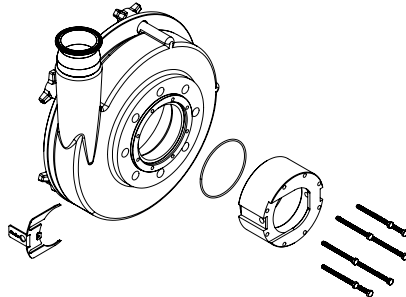

Coil spring option (857/858)

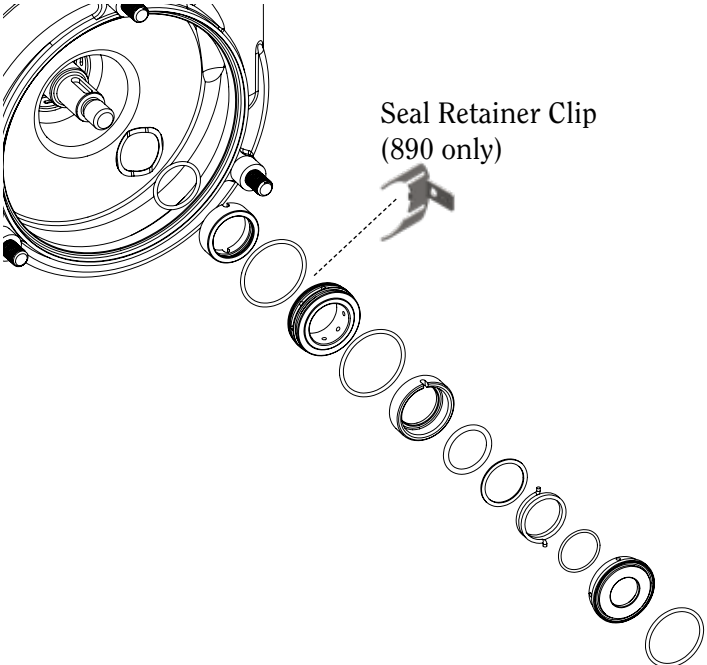

ASSEMBLY (ALL MODELS EXCEPT 4001)

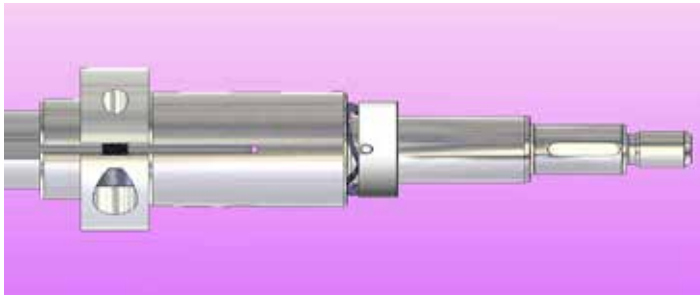

FLUSH SEAL
(if pump has double seal)

Figure 4

Install spring behind shaft pins. Place o-ring into double rotating seal and lubricate. Push seal onto shaft making sure slots align with pins.

(Note: housing and flange removed from picture for clarity)

Single Stationary Seal O-ring

Double Stationary Seal O-ring



STATIONARY SEAL

Figure 5

Single Seal:
Install single stationary seal o-ring and lubricate.

Double Seal:
Install single and double stationary seal o-rings and lubricate.

SEAL HOUSING (890 SEAL / 758 SEAL ON MODEL 3640 ONLY)

Figure 5b

Install seal housing o-ring into seal housing. Install seal housing onto pump housing using seal housing bolts.

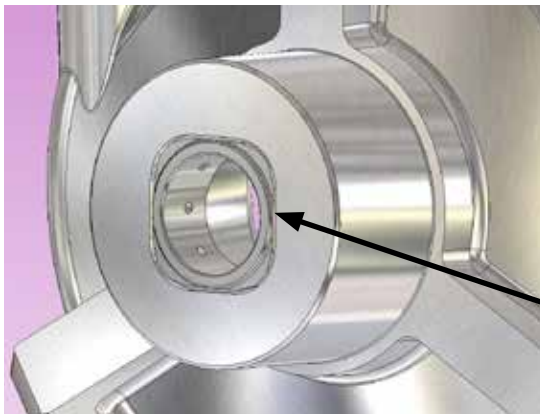

Figure 6

Install the stationary seal into housing making sure to align flats on the seal with the flats on the housing.

890 Seal Only: Re-install the seal retaining clip and install seal retaining clip bolts.

Align flats on housing & seal



ROTATING SEAL - WAVE SPRING STYLE ONLY

Figure 7

Install spring behind seal pins inside the seal driver.



Figure 8

Install single rotating seal o-ring and lubricate. Slide seal driver onto rotating seal making sure to align pins inside the driver with the slots on the seal.

Inner Seal Driver O-ring

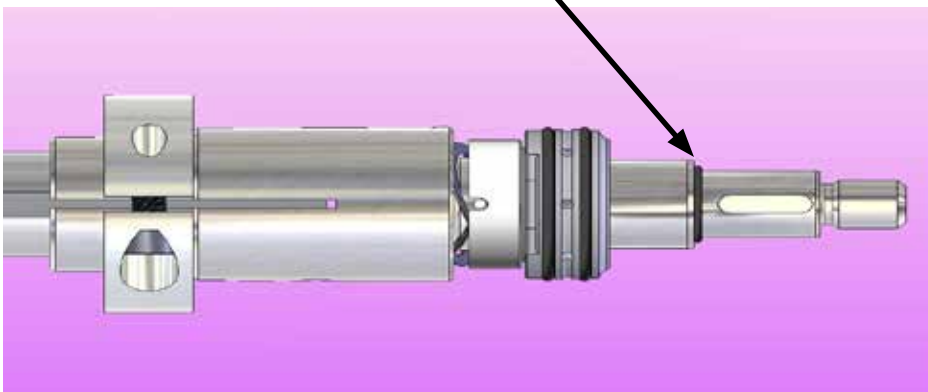
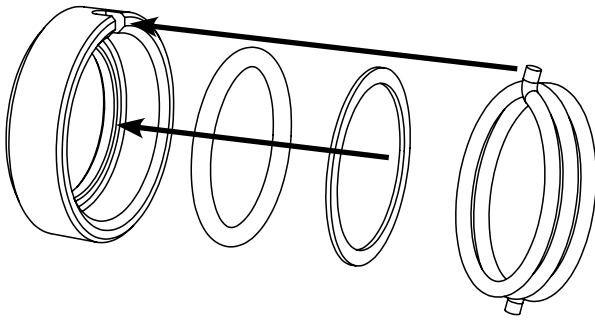

Figure 9

Slide inner seal driver o-ring onto the shaft and lubricate.

(Note: housing and flange removed from picture for clarity)



ROTATING SEAL - COIL SPRING STYLE ONLY

Figure 7C

Lubricate and place the seal o-ring inside the rotating seal.

Place the seal washer into the rotating seal.

Install one end of the seal spring into the rotating seal making sure that the tab of the spring is in the slot on the rotating seal.

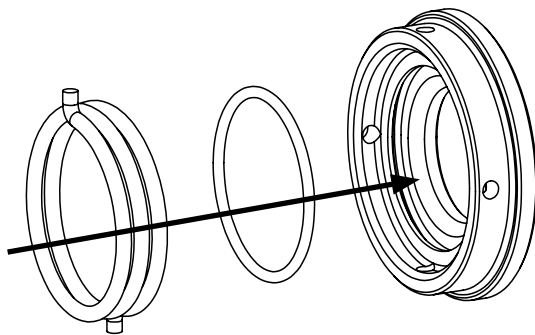
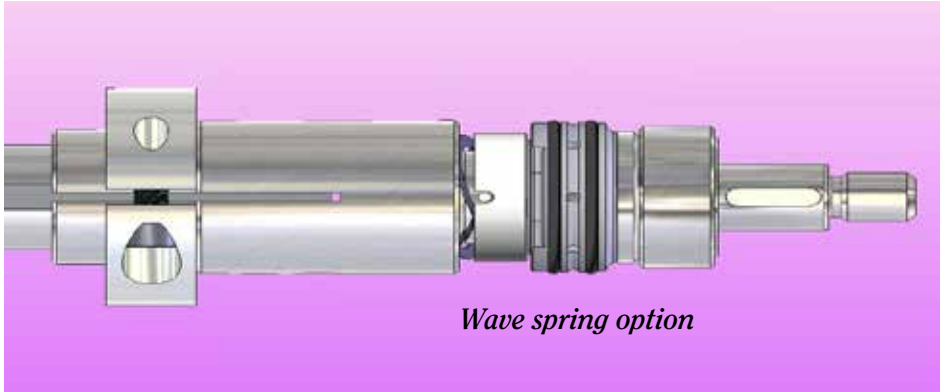

Figure 8C

Lubricate and place the inner seal driver o-ring inside the seal driver.

With one end of the spring already in the slot of the rotating seal, install the tab on the other end of the spring into the one of the holes on the front seal driver.



PUMP ASSEMBLY,
CONTINUED

Figure 10

Slide seal driver assembly onto the shaft.

(Note: housing and flange removed from picture for clarity)

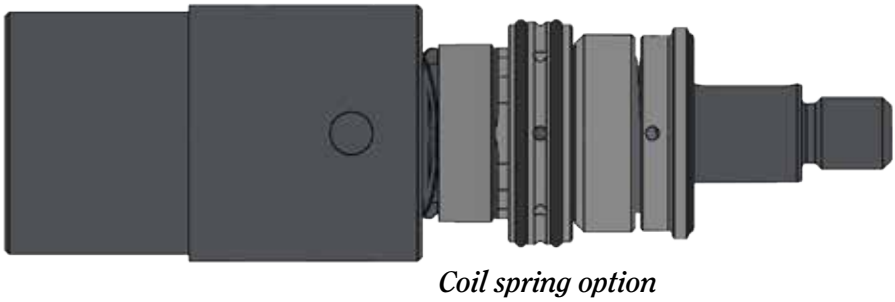

Figure 11

Install impeller key and outer seal driver o-ring. Lubricate o-ring.



Figure 12

Slide impeller onto shaft making sure to align keyway in impeller with key in the shaft.

Lubricate impeller nut gasket and place it onto the impeller nut.

Thread impeller nut onto shaft. Place 3/8" rod or Phillips screwdriver in shaft hole. Use socket with torque wrench and torque nut to proper torque (see page 4).

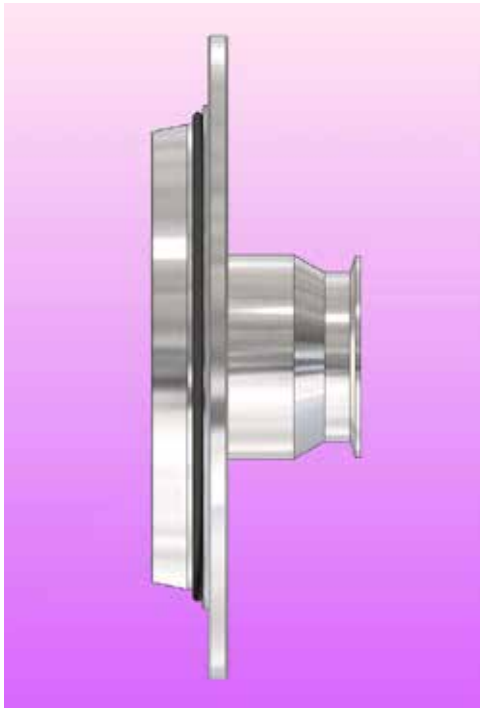

Figure 13

Install cover o-ring.

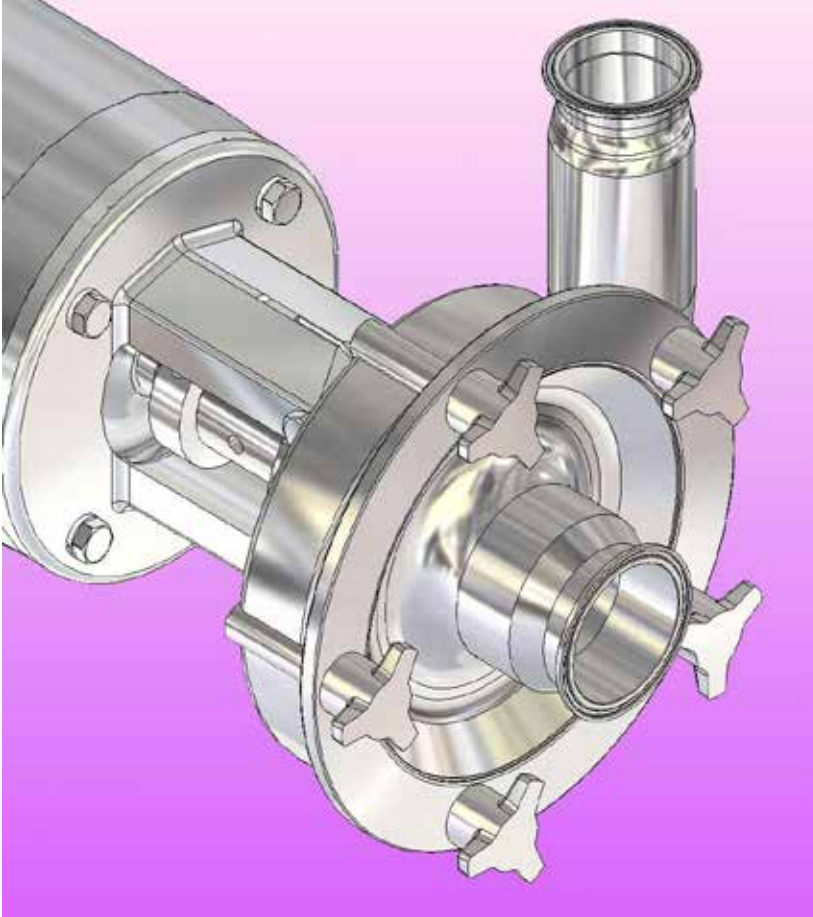

Figure 14

Install cover.

Install cover star nuts and tighten with a soft-faced hammer.

SEAL REPLACEMENT: SIZES 102/859

Begin all pump maintenance by disconnecting the energy source to the pump. Observe all lock out/tag out procedures as outlined by ANSI Z244.1-1982 and OSHA 1910.147 to prevent accidental start-up and injury.

Note: When replacing ANY seal part, it is important that ALL seal wear parts are replaced to ensure seal integrity.

TOOLS FOR SEAL REPLACEMENT

Socket wrench
24mm socket
32mm socket
Ratchet
Pliers (channel locks)
One soft-faced hammer
One 5/16" diameter rod
Optional: One pair impeller pullers (tack pullers)

PUMP HEAD DISASSEMBLY

Note: the reference numbers listed in the text (#) refer to the pump assembly drawing.

Disconnect the suction pipe from the pump.
Drain all fluid from the pump prior to disassembly.

- a) Remove the cover nuts (25) with the 24mm socket.
- b) Remove the pump cover (24) and the cover gasket (21).
- c) Remove the guard nuts (3) and remove shaft guards (4).
- d) Place a 5/16" diameter rod in a hole in the shaft (7). Hold the rod to keep the shaft from rotating while loosening the impeller nut (23) with the socket wrench (Figure 4K-1).
- e) Remove the impeller nut and impeller nut gasket (25).
- f) Remove the impeller (22) from the pump shaft (7) by grasping an impeller blade in each hand and pulling the impeller toward you.
- g) After the impeller is removed, place it on a clean flat surface with the blades facing down. The rotating seal is located in hub of the impeller. Remove and discard the rotating seal (33), o-ring (41) and spring (34).
- h) Next remove and discard the stationary seal (19) by pushing on back of seal and sliding it forward out of the housing. NOTE: To remove the stationary seal on the 859 seal, the seal pin nuts must be loosened first.

For 859 Seals Only - remove the flush seal (15) and spring from the pump shaft and discard.

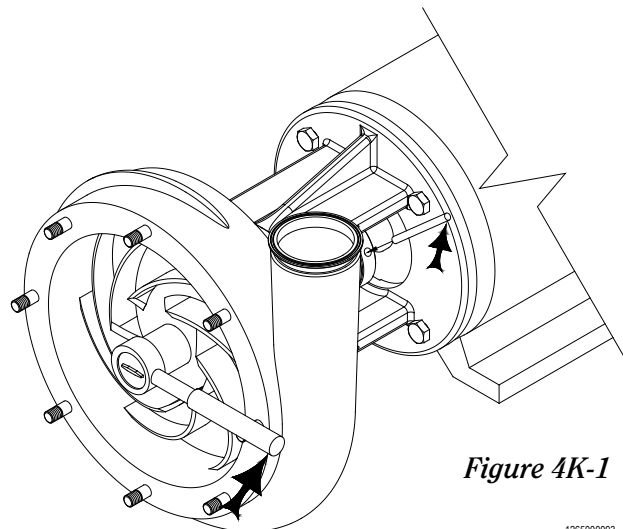

NOTE: when installing the new seal components make sure that you use all of the components supplied with the replacement seal kit. Using some of the old components may reduce seal life. Lubricate all o-rings with a food grade lubricant, unless otherwise specified in the manual.

SEAL INSTALLATION SIZE 102, WAVE SPRING

For Double Mechanical Seals Only

- 1) Generously lubricate the double seal o-ring (14) and install on the double rotating seal (15).
- 2) Install the double seal spring (42) into the back of the double rotating seal.
- 3) Slide the double rotating seal on the pump shaft. Note: Align the grooves in the rotating seal with the pins in the pump shaft. If the seal is installed properly, it will not spin.

For All Mechanical Seals

- 4) Generously lubricate both stationary seal o-rings (18) and install. Improper fit may cause leakage or seal damage.
- 5) Slide the stationary seal (19) onto the pump shaft. Align the flat ends of the stationary seal with the flat edges of the housing (Figure 4K-2).
- 6) Lubricate the rotating seal o-ring (41). Install the rotating seal o-ring onto the rotating seal (33).
- 7) With the impeller, blades on a clean surface, place the single seal spring (34) into the hub of the impeller. Align cuts in spring with pins in the impeller hub.
- 8) Next install the rotating seal into the hub of the impeller (Figure 4K-3). Note: Align the pins in the hub of the impeller with the grooves of the rotating seal. If the seal is installed properly, it will not spin.

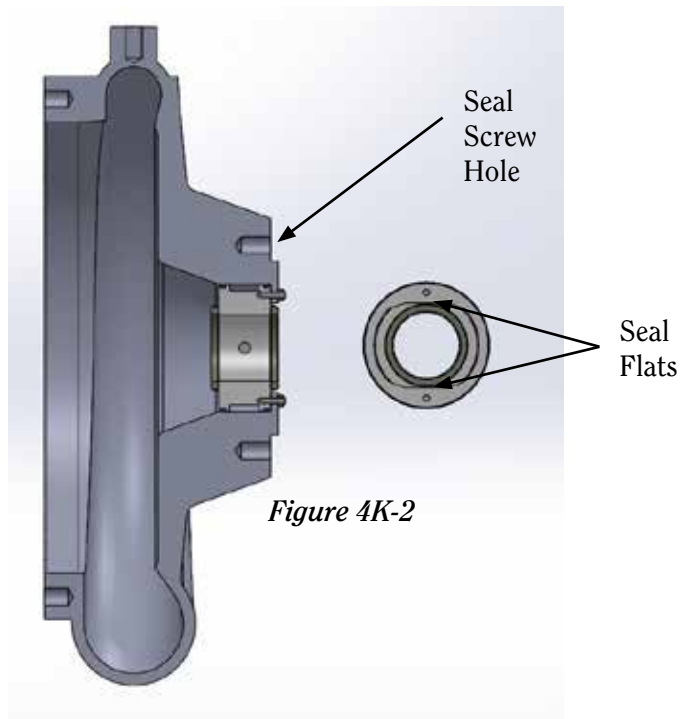

Figure 4K-2

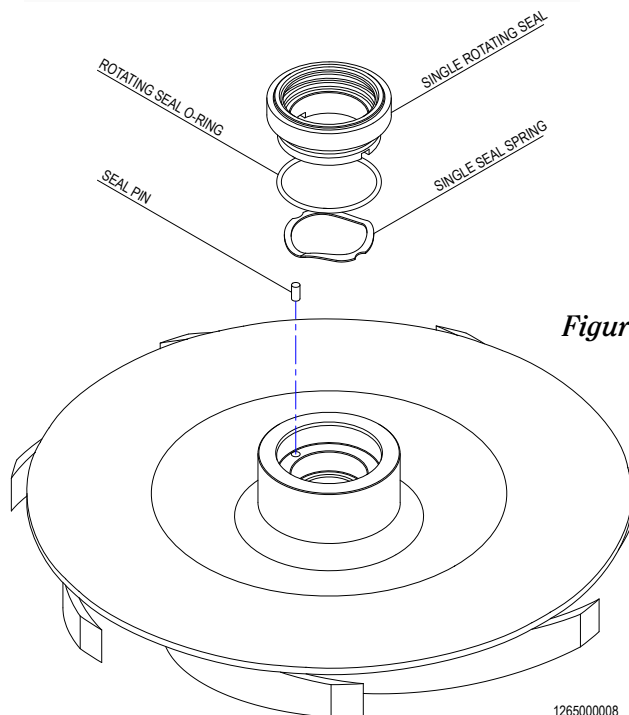
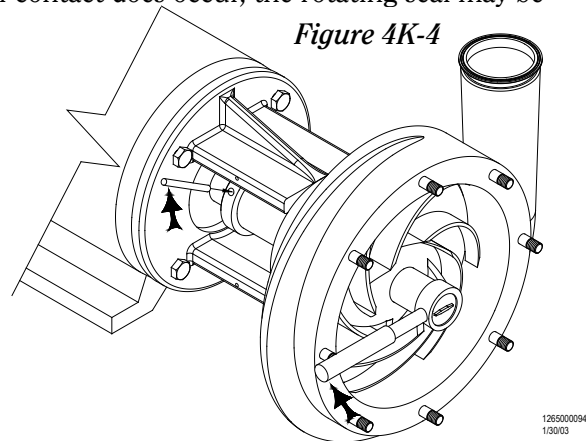

Figure 4K-3

9) Now you are ready to install the impeller. First align the shaft key slot on the impeller with the shaft key on the pump shaft. Now carefully install the impeller, making sure that the rotating seal doesn't make contact with the pumps shaft. If contact does occur, the rotating seal may be damaged or dislodged.

- 10) Lubricate the new impeller nut o-ring (25) and place it onto the impeller nut (23).
- 11) Thread the impeller nut with the o-ring in place onto the pump shaft (7). Place a 5/16" diameter rod in a hole in the shaft (7). Hold the rod to keep the shaft from rotating while tightening the impeller nut with the socket wrench (Figure 4K-4) using a cross-tightening pattern. Check for the proper torque on page 4.



- 12) Now install the new cover o-ring (21) onto the pump cover (24) and install them onto the front of the pump. When placing the cover o-ring into the pump cover, gently stretch the o-ring into position. Do not roll the gasket into position.
- 13) Thread the cover nuts (26) onto the housing studs (238). Make sure the cover o-ring is properly seated in the cover to ensure that it will not get pinched when tightening the cover nuts. Tighten the cover nuts with a 24mm socket (see page 4 for the proper torque).
- 14) Now rotate the pump shaft (7) to make sure that the impeller (22) moves freely. If it does not, recheck your assembly to make sure that gaskets are not pinched and everything is seated properly. Listen to the pump as you turn the shaft. A small amount of noise from the seals is normal, but if there is metal-to-metal contact, the sound will be noticeable. If there is metal-to-metal contact, check the impeller gap. Re-gap the impeller if necessary (see additional instructions). Replace the shaft guards (4) and secure with the guard nuts (3).

Reconnect the suction piping.

WARNING: Mechanical seals must never run dry, even momentarily. Seal damage will result.

SEAL INSTALLATION (859 COIL SPRING SEAL)

- 1) Lubricate all elastomers with food grade lubricant prior to assembly.

For Double Mechanical Seals Only

- 2) Install Flush Seal O-Ring into Flush Seal.
- 3) Install Flush Seal Spring into the back of the Flush Seal.
- 4) Slide the Flush Seal (with O-ring) onto the pump shaft. Align the grooves in the Flush Seal with the pins in the pump shaft.

For all 859 Mechanical Seals

- 5) Install Stationary Seal Pins into Stationary Seal Retainer.
- 6) Install 1 of 2 Stationary Seal Face O-Rings inside Seal Retainer.
- 7) Install Stationary Seal Face into Stationary Seal Retainer.

- 8) Install Stationary Seal Face O-Ring 2 of 2 inside Seal Retainer.
- 9) Install the Stationary Seal Face O-Ring (1 of 2) into the front groove on the outer diameter of the Seal Retainer.
- 10) Install the back Stationary Seal Retainer (2 of 2) into the housing seal bore.
- 11) Now you are ready to install the Stationary Seal Face and Stationary Seal Retainer Assembly into the pump housing. Line the Stationary Seal Pins up with the holes in the housing.
- 12) Fasten Stationary Seal Pin Nuts to Stationary Seal Pins.
- 13) Tighten the Stationary Seal Pin Nuts until the Stationary Seal Retainer is flush with the seal housing.
- 14) Install the Inner Seal Driver O-Ring.
- 15) Now install the Outer Seal Driver O-Ring.
- 16) Install the Rotating Seal O-Ring into the Rotating Seal and install the Rotating Seal Washer.
- 17) Install the Rotating Seal Spring inside one of the four holes of the Seal Driver.
- 18) Install the other end of the Rotating Seal Spring into the slot of the Rotating Seal.
- 19) Ensure the Rotating Seal Face and the Stationary Seal Face are clean. Install the Rotating Seal Assembly over the shaft until the Rotating Seal Face makes contact with the Stationary Seal Face.
- 20) Continue pushing the Seal Driver to compress the Rotating Seal Spring until the Shaft Key can be installed. The key will keep the Seal Assembly in place.

PUMP SHAFT REPLACEMENT

DISASSEMBLY

Disassemble pump as described in Figures 1-3



Figure 15 (models 700-3540 only)

Double Seal Only: Remove water pipe(s) using adjustable pliers.

Use two 3/4" wrenches to loosen the clamping bolt and nut. Remove the housing.



Figure 16 (models 3450, 3550, 3640, 1051, 1161, 3001, & 4001 only)

Double Seal Only: Remove water pipe(s) using adjustable pliers.

Use a 3/4" socket to remove the housing bolts and washers. Remove the housing.

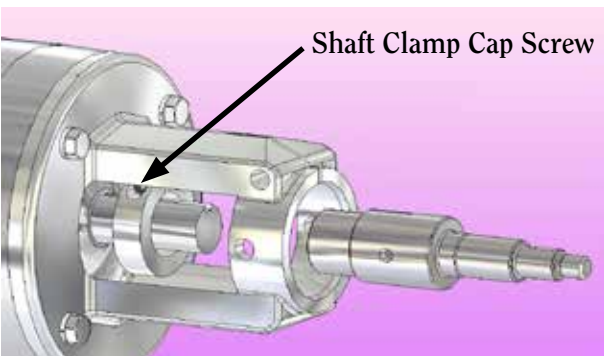
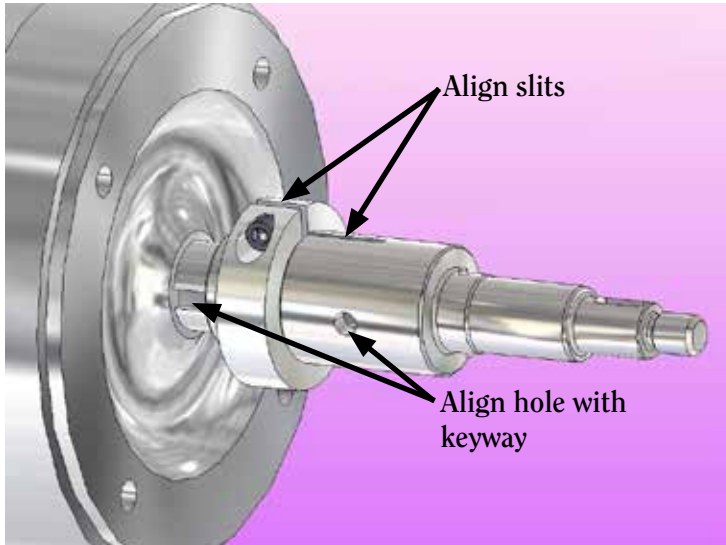

Figure 17

Use an Allen wrench to loosen the shaft clamp cap screw(s). Remove pump shaft.



ASSEMBLY

Figure 18

Install new shaft making sure to align the slit in the shaft with the slit in the shaft clamp. Also align the keyway in the motor shaft with the hole in the pump shaft.

(Note: flange removed for clarity)

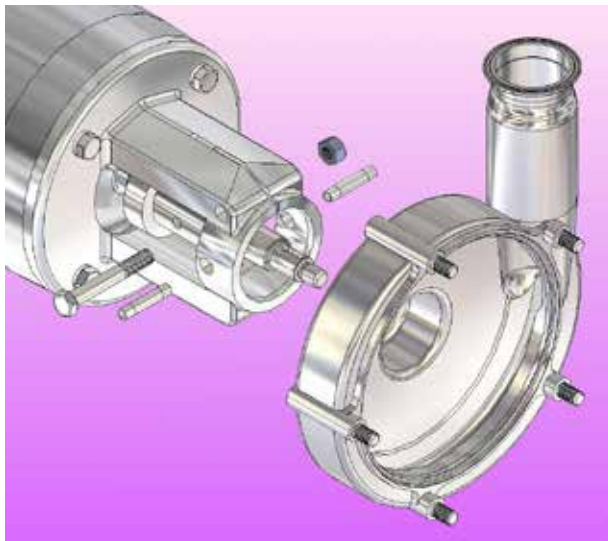

Figure 19 (700-3540 model pumps only)

Install housing hub into the flange. Rotate the housing to align it with the discharge piping.*

Use a 3/4" wrench and a 3/4" torque wrench to torque the clamping bolt to 55 ft-lbs.

*Double Seal Only: Align flush holes in the housing with flush holes in the flange.



Figure 20 (models 3450, 3550, 3640, 1051, 1161, 3001, & 4001 only)

Install housing hub into the flange. Rotate the housing to align it with the discharge piping and align bolt holes.

Install the lockwashers and bolts. Use a torque wrench to torque the bolts to the proper amount.

SETTING IMPELLER-TO-HOUSING GAP

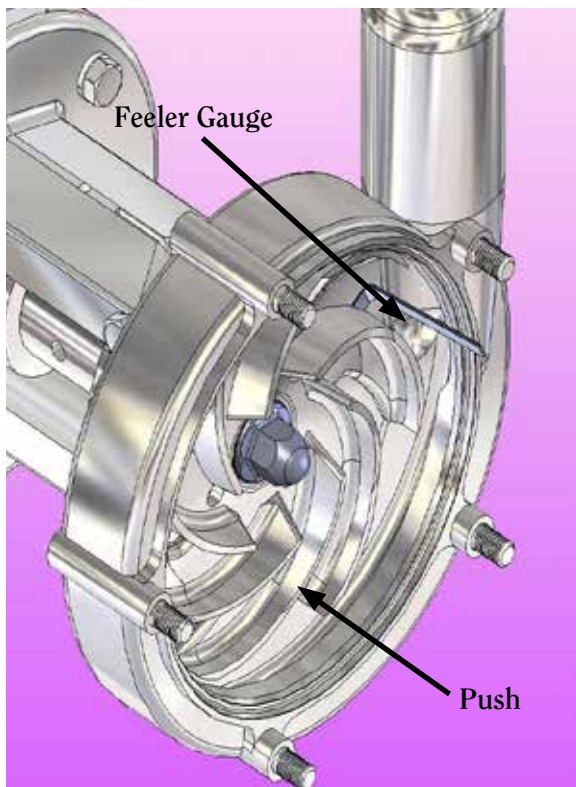

Figure 21-A

Assemble seal as described earlier.

Slide impeller onto shaft making sure to align keyway in impeller with key in the shaft.

Lubricate impeller nut gasket and place it onto the impeller nut. Thread impeller nut with gasket onto pump shaft. Use a torque wrench to tighten the impeller nut to the correct torque value (see page 4).

Slide a feeler gauge between the impeller and housing. The thickness of feeler gauge is determined by the pump model (see page 5 for gauge thicknesses). A plastic feeler gauge may be easier to slide past the lip on the back of the impeller.

Set the impeller-to-housing gap (see figure 21-A) by pushing on the impeller. Once the feeler gauge fits snugly behind the impeller, tighten the shaft clamp bolt with an Allen wrench to the correct torque (see page 4 for torque values).

Remove feeler gauge.

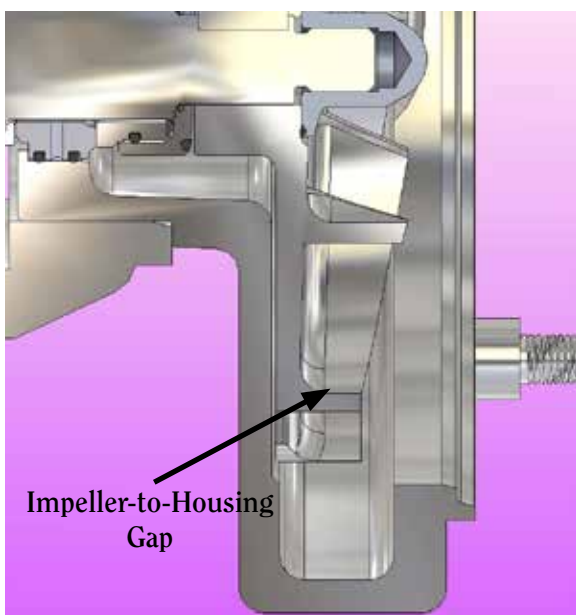

Figure 21-B

The impeller-to-housing gap is measured between the back of the impeller and the housing.

Install cover o-ring, cover and cover nuts as described earlier.

Be sure the shaft freely rotates by hand before operation.

APPENDIX: FPR(S) GAPPING DIFFERENCES

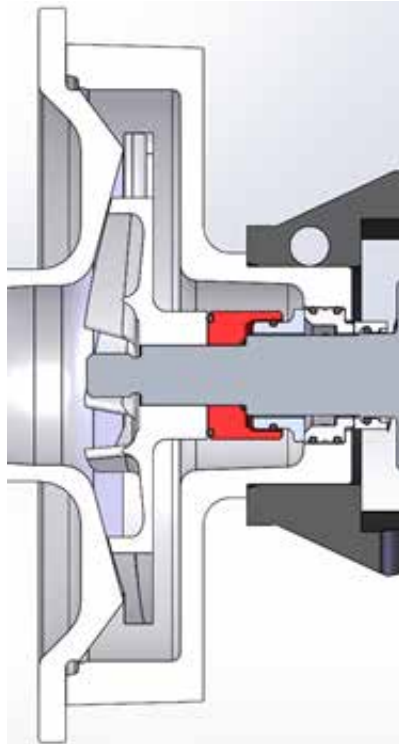

Figure S-1

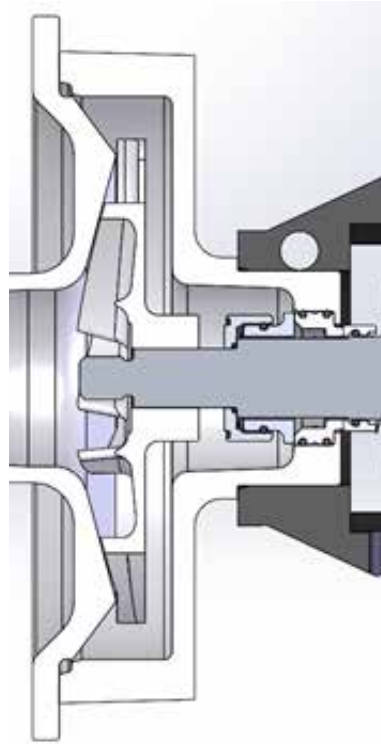

Figure S-2

The FPR(S) functions the same as a standard FPR, but allows a large gap between the back face of the impeller and the product face of the housing. This gap is achieved by a larger seal driver (Fig. S-1). Some models currently require the FPR(S) seal driver to be ordered separately. In those instances, the standard seal driver (Fig. S-2) should be discarded.

The front gap (cover to impeller gap) should be set to 0.5mm (0.020"). To set this gap, Fristam recommends the following:

Tape one or more 0.5mm shims equally spaced to the inside of the cover, ensuring the shim contacts the impeller vanes. Be sure the contact is fully on either the tapered face or flat face of the cover, do not bend the shims as the gap may not be correct.

Bolt the cover on the housing like normal.

Torque the shaft collar to specified value (see page 4 for torque values).

Remove the shims from the inside of the cover.

Install the cover. Be sure the shaft freely rotates by hand before operation.

MOTOR REPLACEMENT

DISASSEMBLY

Disassemble pump as described earlier.
Remove housing and shaft as described earlier.

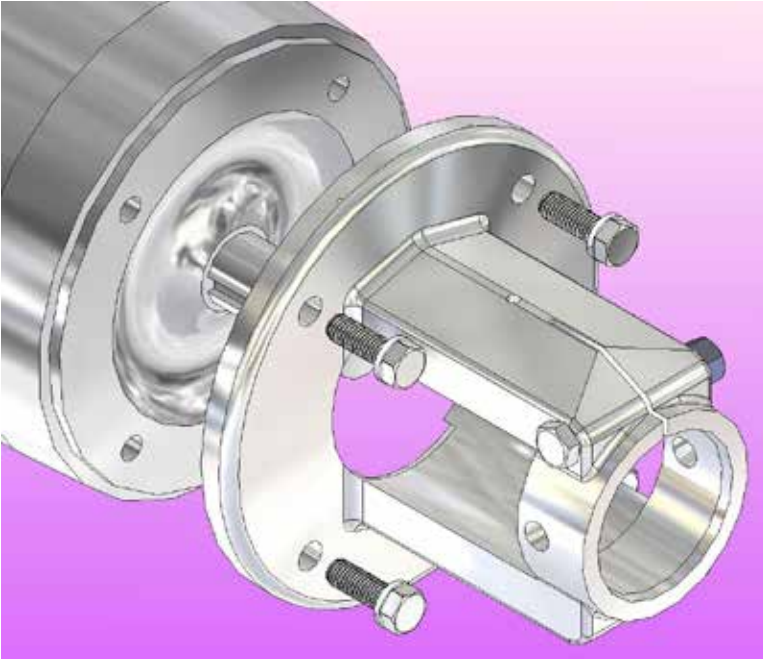

Figure 22

Use a socket to remove the motor bolts and washers. Remove the flange.

ASSEMBLY

Replace motor. Install flange onto motor. Replace bolts and washers. Use a torque wrench to tighten the bolts to the correct torque (see page 4 for torque values).

Install shaft and housing as described earlier.

Assemble seal as described earlier.

Set impeller-to-housing gap as described earlier.

Install cover o-ring, cover and cover star nuts as described earlier.

Replace guard(s) and water pipe(s) if necessary.

NOTICE OF TERMS, WARRANTY PROVISIONS INCLUDING DISCLAIMERS, CLAIMS AND LIMITATION OF LIABILITY

Prices and all terms and conditions of sale are established in current price sheets and are subject to change without notice. All orders are subject to acceptance by Fristam Pumps USA, Limited Partnership.

Each Fristam Pumps item is warranted to be free from manufacturing defects for a period of one (1) year from the date of shipment, providing it has been used as recommended and in accordance with recognized piping practice, and providing it has not been worn out due to severe service, such as encountered under extremely corrosive or abrasive conditions.

This warranty is expressly in lieu of any other warranties expressed or implied, including but not limited to, any implied warranty of merchantability or fitness for particular purpose. All other warranties whatsoever, expressed or implied by law or otherwise, are hereby excluded.

All claims must be in writing and must be mailed or delivered by purchaser within thirty (30) days after purchaser learns of the facts upon which such claim is based. Any claim not made in writing and within the time period specified above shall be deemed waived.

Purchaser's sole and exclusive remedy and Fristam Pumps maximum liability for claims arising hereunder or for negligence for any and all losses and damages resulting from any cause shall be either the repair or replacement of defective items or, at Fristam Pumps' option, the refund of the purchase price for such items. In no event, including in the case of a claim for negligence, shall Fristam Pumps be liable for incidental or consequential damages, including loss of profits.

No person, including any representative employee or agent of Fristam Pumps is authorized to assume on behalf of Fristam Pumps any liability or responsibility in addition to or different from that described in this provision. Any and all representations, promises, warranties or statements that are in addition to or different from the terms of this provision are of no force or effect.

If any provision of this Notice is held to be invalid, such provision shall be severed and the remaining provisions shall continue to be in force.



© 2025 - Fristam Pumps USA Limited Partnership
Drawing # 1250000002 Rev E Updated 1/06/25
Part # 1051000040
Visit www.fristam.com/usa for a current list of documents.

2410 Parview Road • Middleton, WI 53562-2524
1-800-841-5001 • 608-831-5001
Website: www.fristam.com/usa
Email: fristam@fristampumps.com