

FPHP Dimensional Drawing Model: 722

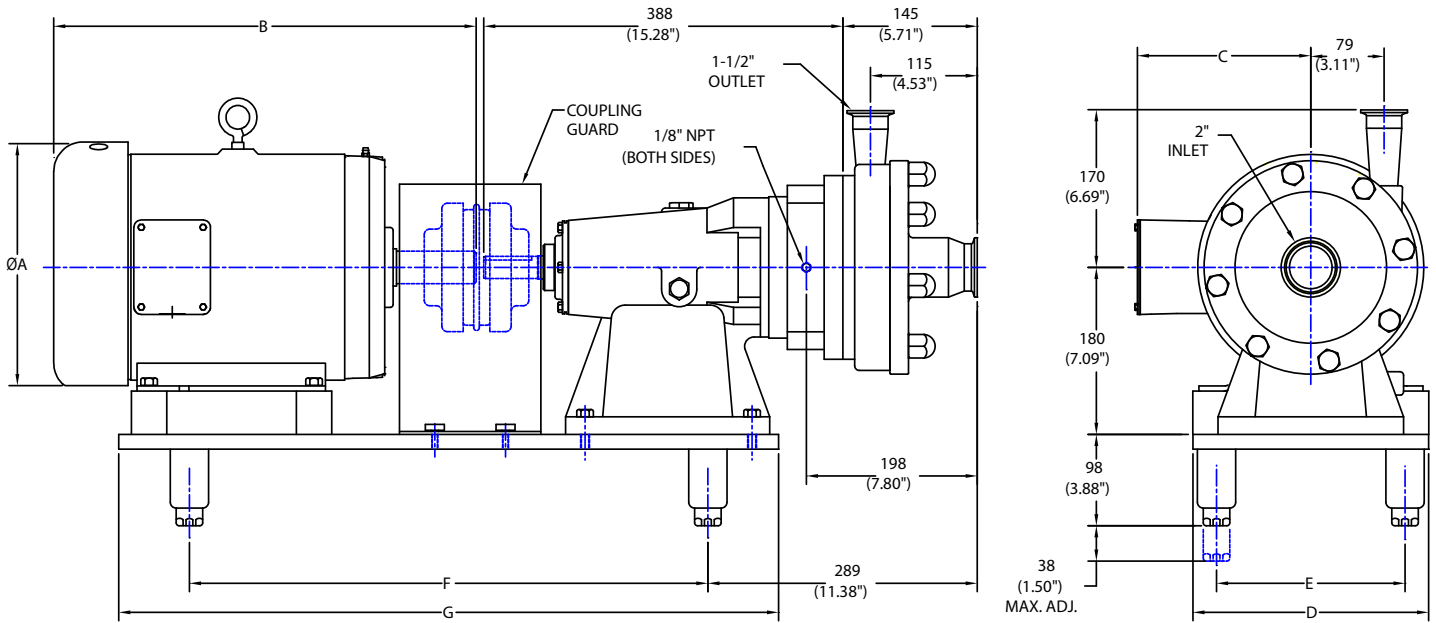

MOTOR HP	NEMA FRAME	ØA	B	C	D	E	F	G
3 HP	182T	216 (8.50")	385 (15.14")	132 (5.21")	279.4 (11.00")	228.6 (9.00")	444.5 (17.50")	596.9 (23.50")
			420 (16.55")	152 (5.97")	279.4 (11.00")	228.6 (9.00")	469.9 (18.50")	622.3 (24.50")
5 HP	184T	263 (10.34")	469 (18.47")	220 (8.67")	279.4 (11.00")	228.6 (9.00")	520.7 (20.50")	673.1 (26.50")
			469 (18.47")	220 (8.67")	279.4 (11.00")	228.6 (9.00")	558.8 (22.00")	711.2 (28.00")

1265000457 REV A

NOTE:

ALL DIMENSIONS ARE IN MILLIMETERS (INCHES) UNLESS OTHERWISE SPECIFIED.

MOTOR DIMENSIONS MAY VARY DEPENDING ON MANUFACTURER REQUESTED.

PUMP DIMENSIONS ARE BASED ON CLAMP FITTINGS.

FPH/FPHP Dimensional Drawing Models: 3542 and 3552

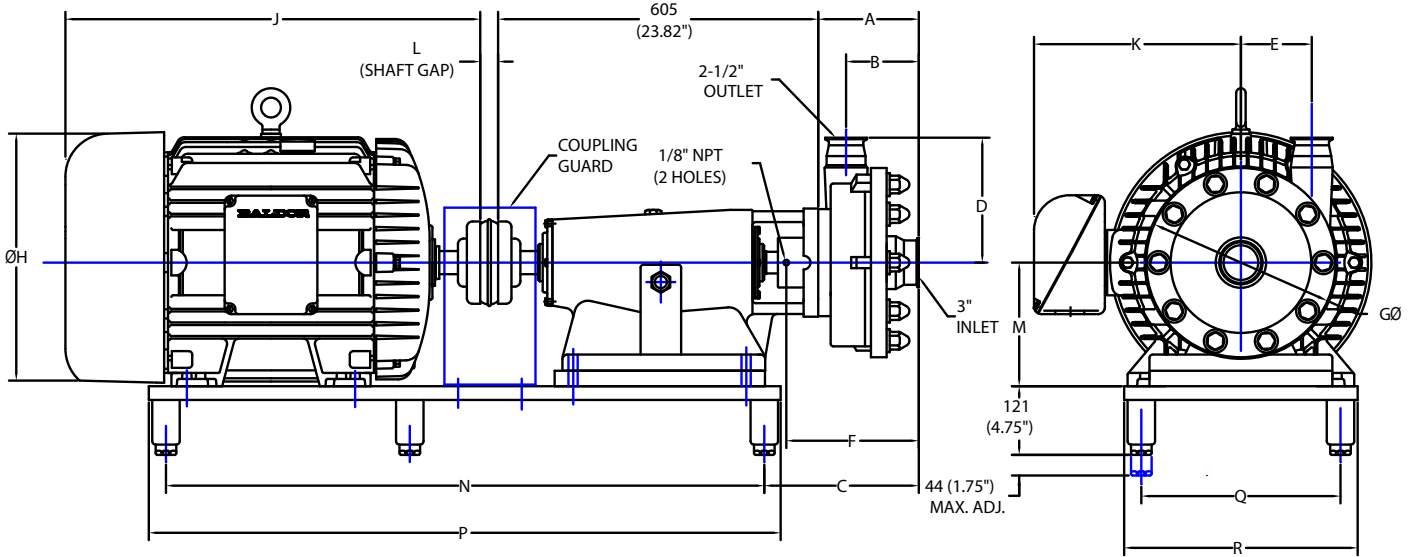

1265000458 REV.

Pump Model	A	B	C	D	E	F	G
FPH & FPHP 3542	165 (6.50")	119 (4.68")	263 (10.35")	211 (8.31")	115 (4.53")	224 (8.82")	290 (11.42")
FPH 3552	171 (6.73")	120 (4.72")	266 (10.59")	231 (9.09")	140 (5.51")	230 (9.06")	350 (13.78")

Motor HP	NEMA Frame	H	J	K	L	M	N	P	Q	R
10 HP	215T	263 (10.34")	469 (18.47")	220 (8.67")	16 (.63")	133 (5.25")	1083 (42.62")	1143 (45.00")	321 (12.62")	381 (15.00")
15 HP	254T	270 (10.62")	536 (21.09")	225 (8.86")	6 (.25")	200 (7.87")	1083 (42.62")	1143 (45.00")	321 (12.62")	381 (15.00")
20HP	256T	270 (10.62")	580 (22.84")	225 (8.86")	6 (.25")	200 (7.87")	1083 (42.62")	1143 (45.00")	321 (12.62")	381 (15.00")
25HP	284TS	395 (15.56")	670 (26.39")	333 (13.11")	19 (.75")	200 (7.87")	1083 (42.62")	1143 (45.00")	321 (12.62")	381 (15.00")
30HP	286TS	395 (15.56")	670 (26.39")	333 (13.11")	19 (.75")	200 (7.87")	1083 (42.62")	1143 (45.00")	321 (12.62")	381 (15.00")
40HP	324TS	430 (16.94")	731 (28.78")	371 (14.62")	6 (.25")	203 (8.00")	1083 (42.62")	1143 (45.00")	321 (12.62")	381 (15.00")
50HP	326TS	430 (16.94")	731 (28.78")	371 (14.62")	6 (.25")	203 (8.00")	1083 (42.62")	1143 (45.00")	321 (12.62")	381 (15.00")
60HP	364TS	483 (19.00")	780 (30.72")	380 (14.96")	6 (.25")	229 (9.00")	1108 (43.62")	1168 (46.00")	371 (14.62")	432 (17.00")
75HP	365TS	483 (19.00")	780 (30.72")	380 (14.96")	6 (.25")	229 (9.00")	1108 (43.62")	1168 (46.00")	371 (14.62")	432 (17.00")

NOTE: All dimensions are in millimeters unless otherwise specified. Motor dimensions may vary depending on manufacturer and model requested. Pump dimensions are based on sanitary clamp fittings.

FPH/FPHP Dimensional Drawing Models: 3642 and 3652

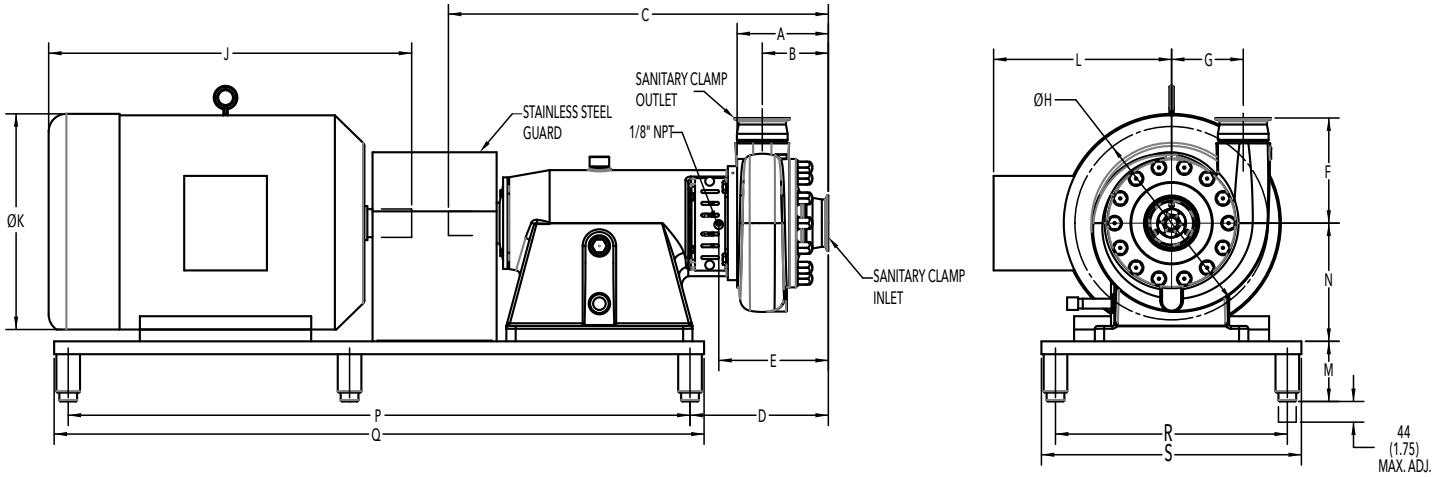

PUMP MODEL	INLET	OUTLET	A	B	C	D	E	F	G	H
FPH 3642	4"	4"	196 7.72"	142 5.59"	824 32.44"	297 11.69"	235 9.25"	226 8.9"	154 6.06"	412 16.22"
FPH 3652	4"	2.5"	179 7.05"	110 4.33"	807 31.77"	250 9.84"	219 8.62"	231 9.09"	140 5.51"	350 13.78"

MOTOR HP	MOTOR FRAME	J	K	L	M	N	P	Q	R	S
40 HP	324TS	731 28.78"	430 16.93"	371 14.61"	121 4.76"	254 10"	1108 43.62"	1169 46"	321 12.64"	381 15"
50 HP	326TS	731 28.78"	430 16.93"	371 14.61"	121 4.76"	254 10"	1108 43.62"	1169 46"	321 12.64"	381 15"
60 HP	364TS	780 30.71"	483 19.02"	380 14.96"	127 5"	254 10"	1336 52.6"	1397 55"	499 19.65"	559 22"
75 HP	365TS	780 30.71"	483 19.02"	380 14.96"	127 5"	254 10"	1336 52.6"	1397 55"	499 19.65"	559 22"
100 HP	405TS	966 38.03"	516 20.31"	457 17.99"	127 5"	254 10"	1336 52.6"	1397 55"	499 19.65"	559 22"
125 HP	444TS	1124 44.25"	581 22.87"	497 19.57"	127 5"	280 11.02"	1336 52.6"	1397 55"	499 19.65"	559 22"
150 HP	445TS	1124 44.25"	581 22.87"	497 19.57"	127 5"	280 11.02"	1336 52.6"	1397 55"	499 19.65"	559 22"

NOTE: All dimensions are in millimeters unless otherwise specified. Motor dimensions may vary depending on manufacturer and model requested. Pump dimensions are based on sanitary clamp fittings.