

NEW Fristam FPR 857/858 Coil Spring Seal

Fristam has developed an alternative FPR centrifugal pump seal for those who prefer the FP/FPX coil spring style seal.

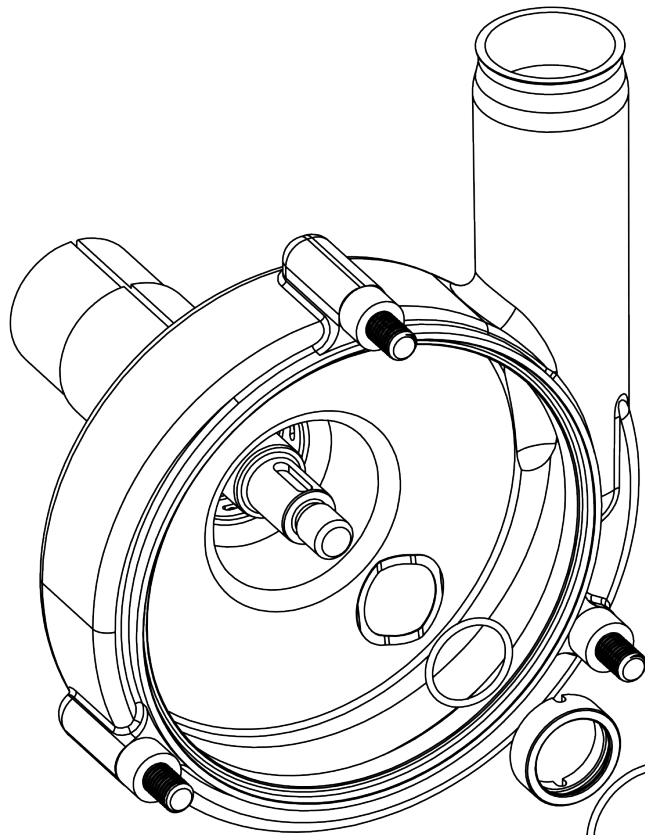

- We've kept the same principles: internal, front-loading, single and double seals.
- There is no change to the pump itself, so (using an entire seal kit) a standard FPR pump can accommodate the new seal or the original wave spring seal.
- The new seals correspond to the two major original seal sizes: the new 857 fits the same models as the 757 and the new 858 fits the same models as the 758.



What is different?

Rotating seal (at right, colored components)

- coil spring (green) instead of wave spring
- metal washer (yellow) added to protect the rotating seal o-ring (blue)
- inner seal driver o-ring (orange, small) sits in a channel in the seal driver (purple) instead of halfway down the extended back end of the original driver

Stationary seal

- dimensions have changed but not function

Flush seal

- no changes

Fristam
PUMPS®

Engineered For Lasting Performance®