

Powder Mixer Dimensional Drawing

There are several standard model sizes, depending on the powder being mixed and the flow rate.

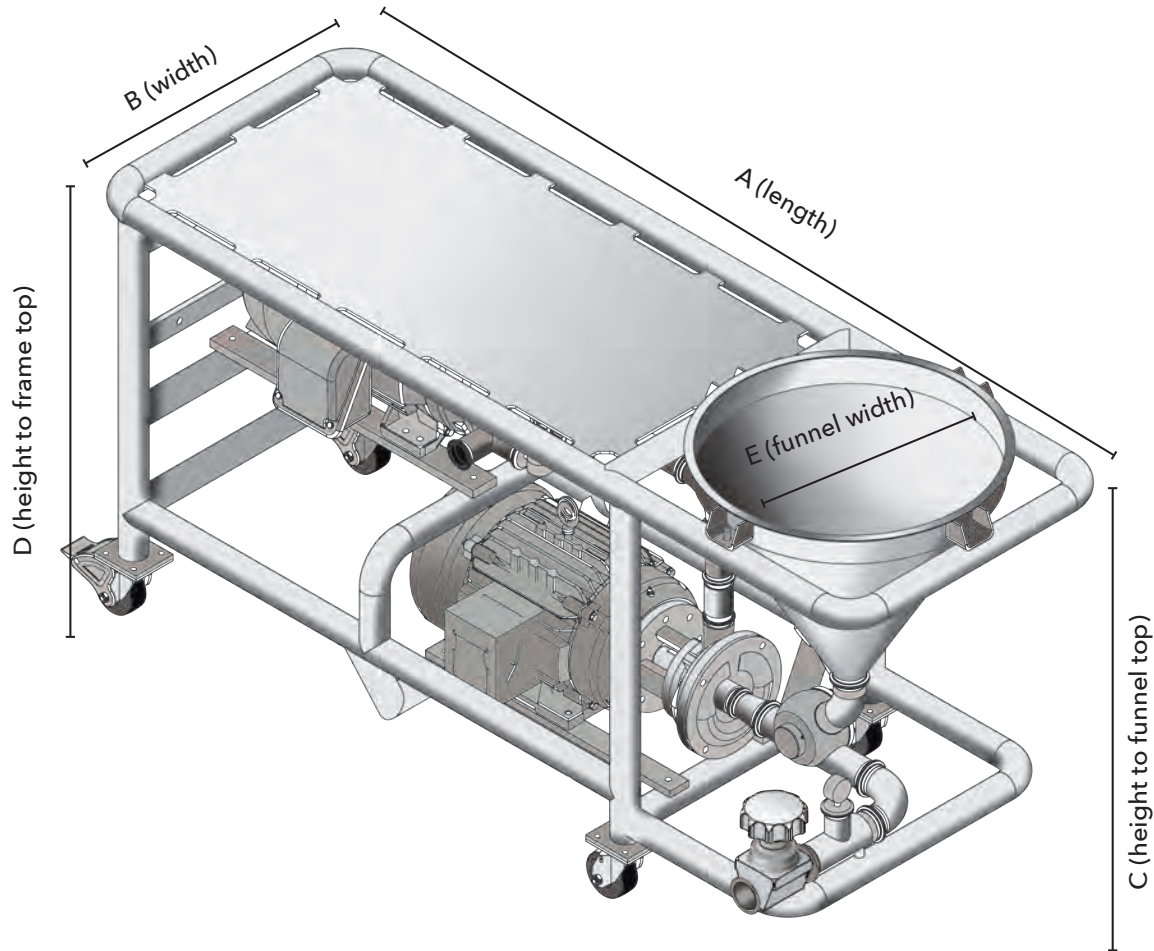

Model	FZX Model	FS Model	Inlet	Outlet	A	B	C	D	E
01-10	2010	712	1.5 (3.8)	1.5 (3.8)	56 (142)	30 (76.2)	36.5 (92.7)	34 (86.4)	12 (30.5)
10-52	2100	3522	2 (5.1)	2 (5.1)	71 (180)	30.5 (77.5)	40.5 (103)	38 (96.5)	24 (61)
15-52	2150	3532	2 (5.1)	2 (5.1)	71 (180)	30.5 (77.5)	41.5 (105)	38 (96.5)	24 (61)
20-53	2200	3532	2.5 (6.4)	2.5 (6.4)	83 (211)	30.5 (77.5)	41.5 (105)	39 (99.1)	24 (61)
25-53	2250	3532	2.5 (6.4)	2.5 (6.4)	83 (211)	30.5 (77.5)	41.5 (105)	39 (99.1)	24 (61)
2-52	FDS 2	3522	2 (5.1)	2 (5.1)	83 (211)	30.5 (77.5)	41.5 (105)	39 (99.1)	24 (61)
3-53	FDS 3	3532	3 (7.6)	2 (5.1)	104 (264)	35 (89)	45.8 (116)	43.2 (110)	24 (61)

All dimensions are in inches (centimeters).