



Instruction and Maintenance Manual

FCM Colloid Mixer (Original Instructions)



For more information see:
www.fristam.com/fcm

DESCRIPTION

This manual contains installation, operation and repair instructions for the Fristam FCM Colloid Mixer.

CAUTION: BEGIN ALL MIXER MAINTENANCE OPERATIONS BY DISCONNECTING THE ENERGY SOURCE TO THE MIXER. OBSERVE ALL LOCK OUT/TAG OUT PROCEDURES AS OUTLINED BY ANSI Z244.1-1982 AND OSHA 1910.147 TO PREVENT ACCIDENTAL START-UP AND INJURY.

SAFETY

This instruction and maintenance manual shall be read and completely understood prior to operation of the mixer. The manual should be kept available at the mixer's installation location.

All applicable local/national regulation and laws shall be followed.

All work described herein may only be performed by qualified personnel.

Personal protective equipment (PPE) such as hearing protection may be required.

Despite inherent safe design measures some amount of residual risk will remain. Throughout the manual these risks will be pointed out.

CAUTION:  Begin all mixer maintenance operations by disconnecting the energy source to the mixer. Observe all lock out/tag out procedures as outlined by ANSI Z244.1-1982 and OSHA 1910.147 to prevent accidental start-up and injury.

TABLE OF CONTENTS

- Safety2
- Technical Information4
- Mixer Operations 6
- General Guidelines7
- General Guidelines7
 - Use of Non-OEM Spare Parts.....7
 - Transportation.....7
 - Noise Reduction.....7
 - Cleaning.....7
- Installation8
- Recommended Preventive Maintenance.....12
- Gap Adjustment13
- Drawing and Illustrations14
 - Mixer Assembly and Parts List.....14
 - 2VR Bearing Block Assembly and Parts List15
 - Double Mechanical Assembly16
- Mixer Disassembly.....17
- Seal Replacement18
- Mixer Assembly.....19
- Stator Assembly20
- 2VR Bearing Block Disassembly21
- 2VR Bearing Block Assembly22
- Mixer Maintenance Record.....24
- Warranty27
- End-of-Life Disposal27

TECHNICAL INFORMATION

SPECIFICATIONS

Max. Inlet Pressure.....	250 PSI
Max. Speed Range.....	3600 RPM
Max. Motor Power.....	40 HP
Max. Viscosity.....	1,000,000 cps
Max. Flow Rate (product).....	50 GPM
Max. Flow Rate (CIP).....	100 GPM
Rotation.....	Reversible
Mounting.....	Horizontal
Max. Temperature.....	302°F
Standard Fitting Size.....	3 in. cover / 3 in. housing

MATERIALS OF CONSTRUCTION

Major Product Contact Components.....	AISI 316L
Cover Gasket.....	Viton®
Also available in.....	EPDM and other options available
Surface Finish for Product Contact Surfaces.....	32 Ra (standard)

SHAFT SEALS & O-RINGS

Mechanical Seal Type.....	Double
Outer Stationary Seal.....	Carbon
Outer Rotating Seal.....	Tungsten Carbide
Other O-rings (mechanical seals).....	Viton® (standard)
Also available in.....	EPDM and other options available

LUBRICATION

Bearing Block Oil.....	ISO VG 68
Oil Capacity.....	0.95L (1 US quart)

RECOMMENDED TORQUE VALUES

Cover Bolt.....	45-ft lb / 61 Nm
Housing Bolt.....	50-ft lb / 68 Nm
Rotor Bolt.....	118-ft lb / 160 Nm
Bearing Cover Bolt.....	10-ft lb / 14 Nm
Seal Retainer Bolt.....	7-ft lb / 9 Nm

REQUIRED TOOLS

Cover Bolt.....	19 mm socket wrench
Housing Bolt.....	9/16" socket wrench
Rotor Bolt.....	30 mm socket wrench
Bearing Cover Bolt.....	1/2" mm socket wrench
Seal Retainer Bolt.....	10 mm socket wrench

OPERATIONS

INTENDED USE

The standard Fristam FCM Colloid Mixer versions are designed for use in hygienic applications. Each mixer is customized according to customer specifications, including performance and materials of construction. The mixer may only be used for the application it was specified for.

IMPROPER USE

The standard Fristam FCM Colloid Mixer versions may not be used in explosive atmospheres. Special explosion-proof versions may be available. Please consult Fristam for more information.

Transferring media other than those specified can cause serious damage to the equipment and/or personnel. Any modifications to the mixer or its use are only permissible with the explicit consent of Fristam.

START-UP INSTRUCTIONS - SEE PAGE 11

SHUT-DOWN INSTRUCTIONS

- Shut off the power supply to the mixer.
- Close the shut-off valves in the suction and discharge piping.
- Drain and clean the mixer.
- Protect the mixer against dust, heat, moisture and impact damage.

GENERAL GUIDELINES

USE OF NON-OEM SPARE PARTS

Use of replacement parts that are not approved by Fristam Pumps can lead to serious personal injury and material damage. If you have any questions regarding approved replacement parts, please contact Fristam.

TRANSPORTATION

Transportation may only be performed by trained personnel. The mixer may be moved using approved lifting devices suitable for the weight/size of the mixer. Improper securing of the mixer may result in injury from falling, tipping, or unsecured parts. Dimensional information is available for download at www.fristam.com/usa. Weight information is based on motor selection, and is available upon request.

NOISE REDUCTION

Operating the mixer within its intended design range will aid in reducing the noise to acceptable levels.

- Avoid excessively low or very high flow rates.
- Avoid cavitation of the mixer.
- Maintain good piping practices (see below).

CLEANING

SIP PROCESS

FCM Colloid Mixers should only be used for SIP (Sterilization In Place) process with the prior approval of Fristam. Suitability may depend on selected elastomers and/or process temperatures.

CIP PROCESS

FCM Colloid Mixers are suitable for the CIP (Cleaning In Place) process. The following is a general example of the CIP process:

- Preliminary flush with water
- Caustic flush (NaOH, ~1-2%)
- Intermediate flush with water
- Acid flush (HNO₃, ~1%)
- Final flush with water

The mixer's differential pressure should be sufficient to achieve adequate flow rates for proper cleaning. The result of the CIP process is dependent on many factors (temperature, time, chemical compositions/concentrations, speed, differential pressure, e.g.). Therefore, it is recommended that the cleaning cycle is validated prior to being put into service.

INSTALLATION

UNPACKING

Check the contents and all wrapping when unpacking the mixer. Inspect the mixer carefully for any damage that may have occurred during shipping. Immediately report any damage to the carrier. Keep the protective caps over the inlet and outlet in place until you are ready to install the mixer.

INSTALLING

Prior to installing the mixer, ensure that:

- The mixer will be readily accessible for maintenance, inspection and cleaning.
- Adequate ventilation is provided for motor cooling.
- The drive and motor type is suitable for the environment where it is to be operated. Mixers intended for use in hazardous environments e.g., explosive, corrosive, etc., must use a motor and drive with the appropriate enclosure characteristics. Failure to use an appropriate motor type may result in serious damage and/or injury.

PIPING

CAUTION: Due to the FCM Mixer's minimum gap precision, the user needs to ensure that the mixer will not be over-pressurized during operation as this can cause severe damage to the mixer. The mixer warranty is void for damage caused by over-pressurization. The pressure can be determined by putting a pressure gauge at the inlet side of the mixer.

Follow good piping practices when installing the FCM Colloid Mixer:

- Support all piping independently to minimize the forces exerted on the mixer.
- Verify that the piping layout accounts for thermal expansion to avoid imposing mechanical strain on the mixer's connections.
- Slope inlet piping up to mixer to avoid air pockets.

- Avoid sump areas where sediment may collect (figure 3).
- Use a check or “foot” valve on the inlet side of the mixer in lift applications to keep the suction piping flooded.
- Avoid throttling valves in the suction piping.
- Keep suction lines as short and direct as possible.
- Avoid abrupt transitions in the piping systems (figure 4).
- Avoid the formation of air pockets in the piping (figure 5).
- Ensure that the NPSH available in the system is greater than NPSH required by the mixer.
- Avoid abrupt closure of shut-off valves, this may cause hydraulic shock which can cause severe damage to the mixer and system.
- Avoid elbows in the suction line if possible. When necessary they should be located 5 pipe diameters away from the mixer inlet and have a bend radius greater than 2 pipe diameters (figure 6).
- Install a relief valve on the discharge side of the mixer with a bypass loop back to the suction side to ensure that the mixer cannot be over-pressurized.

FIGURE 3

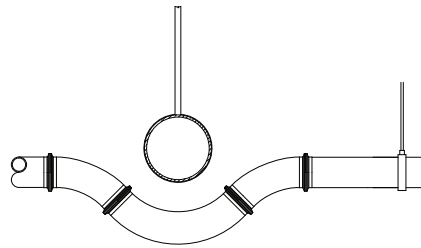
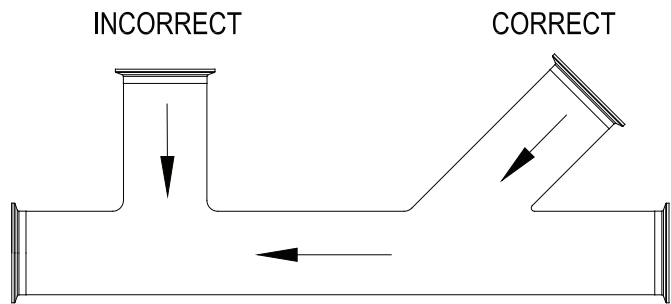

FIGURE 4



1265000245
REV. -

FIGURE 5

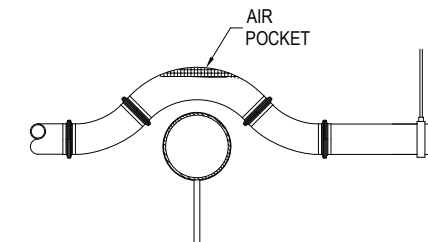
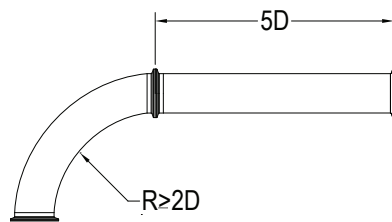

FIGURE 6



ALIGNMENT

In most cases, the mixer will be shipped with a drive unit mounted on a baseplate. The drive and mixer are aligned at the factory; however, this alignment should be checked after installation (Figure 7).

Misalignment between the mixer and drive can result in premature bearing failure or other damage.

If the mixer is not shipped with a drive unit, use a flexible coupling between the mixer and drive unit.

Align the mixer and drive unit according to the coupling requirements.

To check the alignment:

- Remove the wire ring from the coupling sleeve and let it hang between the sleeve and one of the flanges.
- To check the parallel alignment place a straight edge across the two coupling flanges and measure the maximum offset at various points around the periphery of the coupling without rotating the coupling. If the maximum offset (“A”) exceeds the figure shown under “Parallel” in the table below, realign the shafts.
- Check the angular alignment with a micrometer or caliper. Measure from the outside of one flange to the outside of the other (“Y”) at intervals around the periphery of the coupling. Determine the maximum and minimum dimensions without rotating the coupling. The difference between the maximum and minimum must not exceed the figure given under “Angular” in the table referenced below. If a correction is necessary, be sure to recheck the parallel alignment.
- Reinstall the wire ring on the O.D. of the coupling sleeve.

FIGURE 7

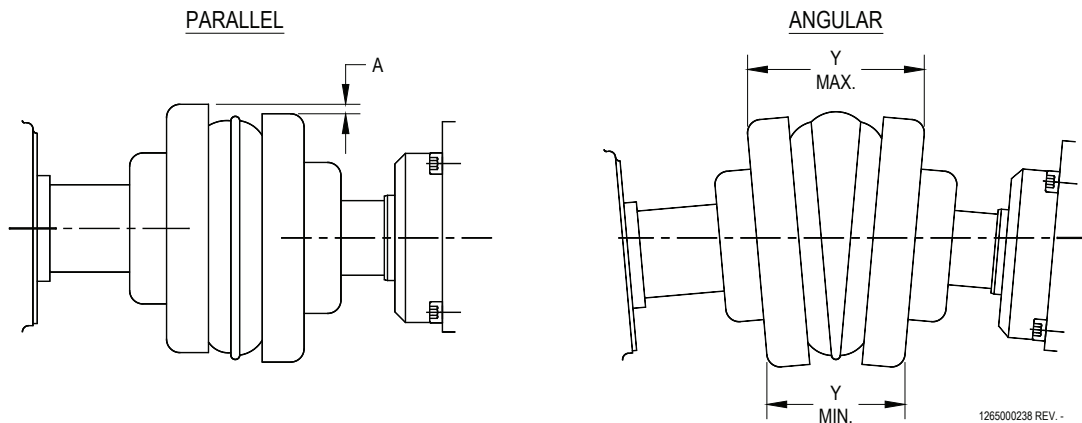

ELECTRICAL CONNECTIONS

Have an electrician connect the drive motor using sound electrical practices. Ensure that proper motor overload protection is provided. The size of the drive selected should meet the requirements of the operating conditions. A change in conditions (for example, higher viscosity product, higher differential pressure) can overload the motor. For technical assistance regarding operating condition changes, please contact Fristam.

WATER FLUSH CONNECTIONS

The mixer is equipped with a double mechanical product seal, and water must be supplied to provide cooling and lubrication. Connect supply and return lines to the water pipes supplied with the product seal on the mixer.

This unit is equipped with a buffer fluid channel around the stator. The buffer fluid lubricates the mechanical seal and prevents contamination when adjusting the rotor/stator gap.

Flush recommendations: Fluid: should be maintained at the exit/drain not to exceed 113°F. Flow rate: 16 gal/hr (1/4 gpm). Pressure: not to exceed 10 PSI.

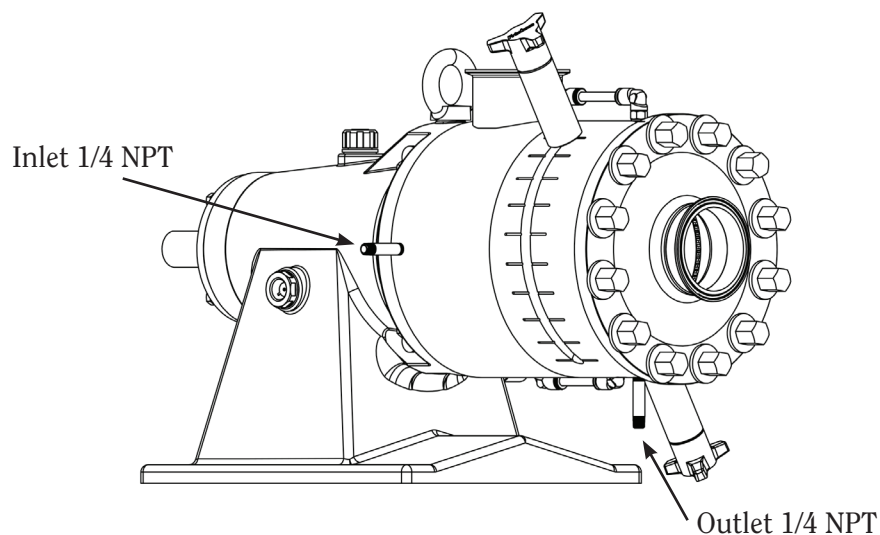

START-UP CHECK-LIST

- Make sure that the mixer and piping system are clear of any foreign matter. Do not use the mixer to flush the system.
- Check that the shaft rotates with no resistance.
- Make sure that the mixer and drive are properly lubricated (see Technical Information section). See instructions from the manufacturer for the drive.
- Check to make sure that all guards are in place and secure.
- Make sure that the mixer is flooded with product. Running the mixer dry even momentarily can cause seal damage (except double seal).
- Check that all valves on the discharge side are open to prevent over-pressurizing the mixer.
- Place an in-line screen (mesh size >1.0 mm) before the mixer inlet to ensure no foreign objects run through the mixer and alter critical clearances.

RECOMMENDED PREVENTIVE MAINTENANCE

RECOMMENDED SEAL MAINTENANCE

Visually inspect mechanical seal daily for leakage.

Replace mechanical seal annually under normal duty.

Replace mechanical seal as often as required under heavy duty.

When replacing ANY seal part, it is important to replace ALL seal wear parts.

LUBRICATION

The bearings and gears are lubricated with ISO VG 68 synthetic oil. *Note: other lubricants are available.* The oil level should be maintained in the center of the sight glass on the side of the bearing block. The oil should be changed every 4,000 hours under normal conditions and every 2,000 hours under severe conditions such as washdown applications.

See the oil capacity listing in the Technical Information section.

PERIODIC MAINTENANCE

Periodically inspect the mixer housing, cover, rotor, and stator for any signs of wear or damage. If wear is present this could be a sign of over-pressurization, incorrect gaps or bearing wear.

TEMPERATURE DIFFERENTIALS

Mixer efficiency depends on internal clearances between the rotor and the stator. Because of the tight clearances, temperature differential* is a concern, because if there is a severe temperature change in the mixer, the shaft and screws may expand inside the mixer housing. This expansion can result in rotor or housing damage. Enough time must be provided for natural thermal expansion and contraction to occur.

** For example, if you are running CIP solution at 180°F and the product is 50°F, that is a 130°F temperature differential.*

ADJUSTING THE GAP

It is not necessary to disassemble the mixer in order to change the width of the gap.

The casing channel is marked with minimum (0.2 mm) and maximum (2.0 mm) values and percentages in between.

To adjust the gap, loosen the 2 star nuts and rotate the levers to the desired position. Tighten the star nuts to maintain positional accuracy.

If the stator does not slide by hand, check the following:

- 1) Straightness of the threaded guide studs*
- 2) Pinched, rolled, or swollen buffer fluid O-rings (sealing the outer diameter of the stator, Pos 120 in exploded view on next page)*

FCM ASSEMBLY AND PARTS LIST

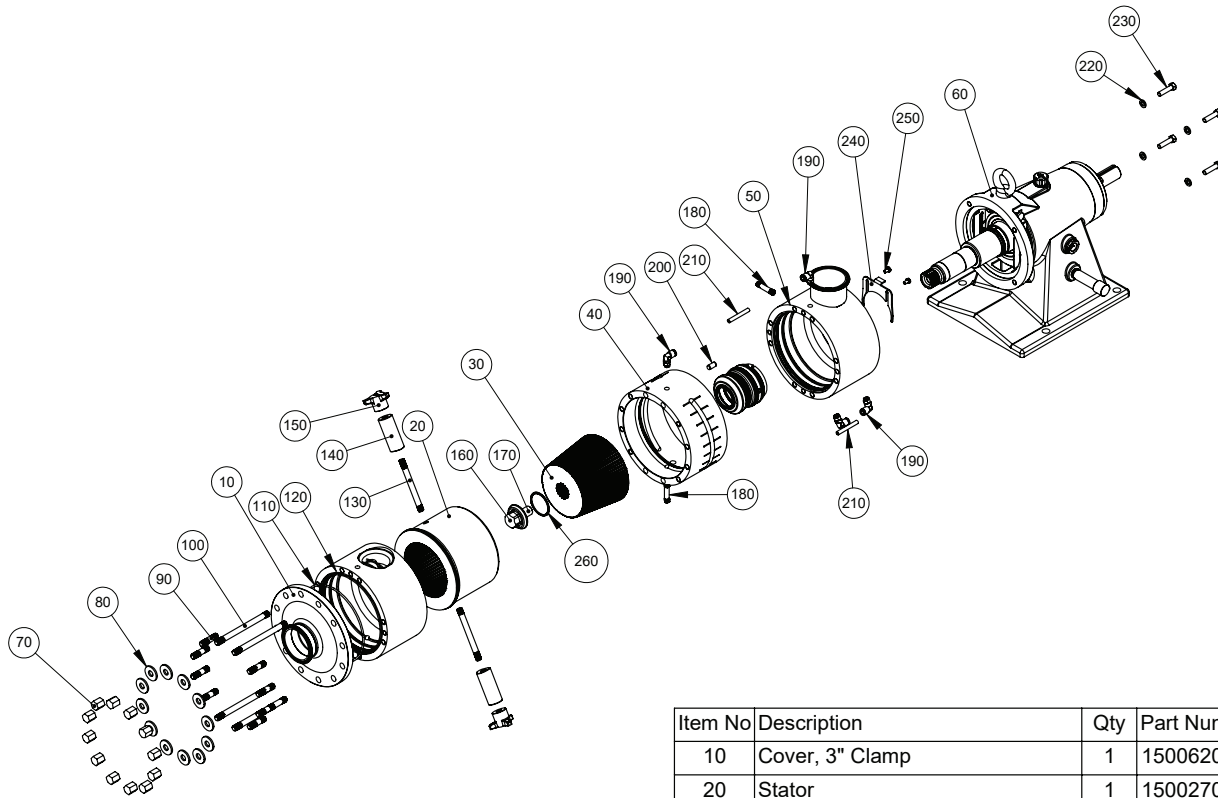

Item No	Description	Qty	Part Number
10	Cover, 3" Clamp	1	1500620000
20	Stator	1	1500270000
30	Rotor	1	1500630000
40	Casing	1	1500670000
50	Housing	1	1500610000
60	Bearing Block Ass'y	1	1349000039
70	Acorn Nut	12	1103000018
80	Washer	12	1104000002
90	Stud, 48mm Long	8	1103000101
100	Stud, 158mm Long	4	1103000188
110	O-Ring, Viton®	1	1180000015
120	O-Ring, Viton®	4	1180001305
130	Stud, 122mm Long	2	1103000123
140	Spacer	2	1102000070
150	Star Nut	2	1103000020
160	Screw Nut	1	1103006300
170	Screw Stud, 35mm Long	1	1103006406
180	Water Pipe, 1/8" NPT	2	1910000000
190	Fitting, Push-to-Connect	4	1912000375
200	Pin	1	1891000073
210	Blue Tubing, PVC	4.75"	1912000025
220	Lock Washer	4	1104000036
230	Hex Head Screw	4	1101000106
240	Mechanical Seal Retainer	1	1148000052
250	Hex Head Screw	2	1101018628
260	Screw Nut Gasket	1	0240800055

2VR BEARING BLOCK ASSEMBLY AND PARTS LIST

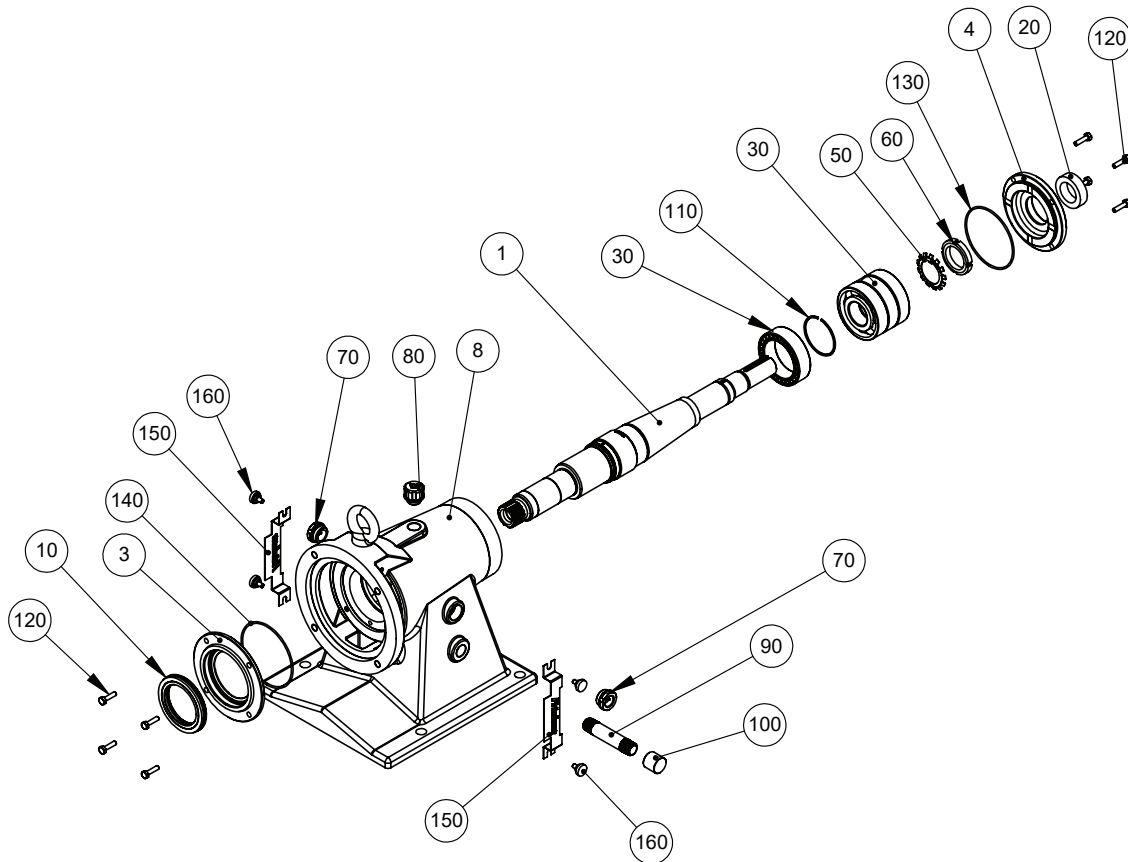

Item No	Description	Qty	Part Number
1	Shaft, 2VR BB	1	1321000404
2	Bearing Block, 2VR	1	1310600284
3	Front Bearing Cover, 2VR BB	1	1303000018
4	Rear Bearing Cover, 2VR BB	1	1303000019
10	Bearing Isolator	1	1812000082
20	Bearing Isolator	1	1812000058
30	Bearing, Front Needle	1	1173001032
40	Bearing, Rear Angular Contact	3	1173001033
50	Bearing Lock Nut Washer	1	1104001051
60	Bearing Lock Nut	1	1306000112
70	Oil Sight Glass	2	1248000018
80	Vent Plug	1	1248000034
90	NPT Fitting	1	1226000006
100	NPT Fitting Cap	1	1226000007
110	External Retaining Ring	1	1148000046
120	Hex Head Bolt	8	1101000238
130	O-Ring	1	1180000148
140	O-Ring	1	1180000225
150	Bearing Block Guard	2	1936000264
160	Flange Guard Knob	4	1102000000

DOUBLE MECHANICAL SEAL ASSEMBLY

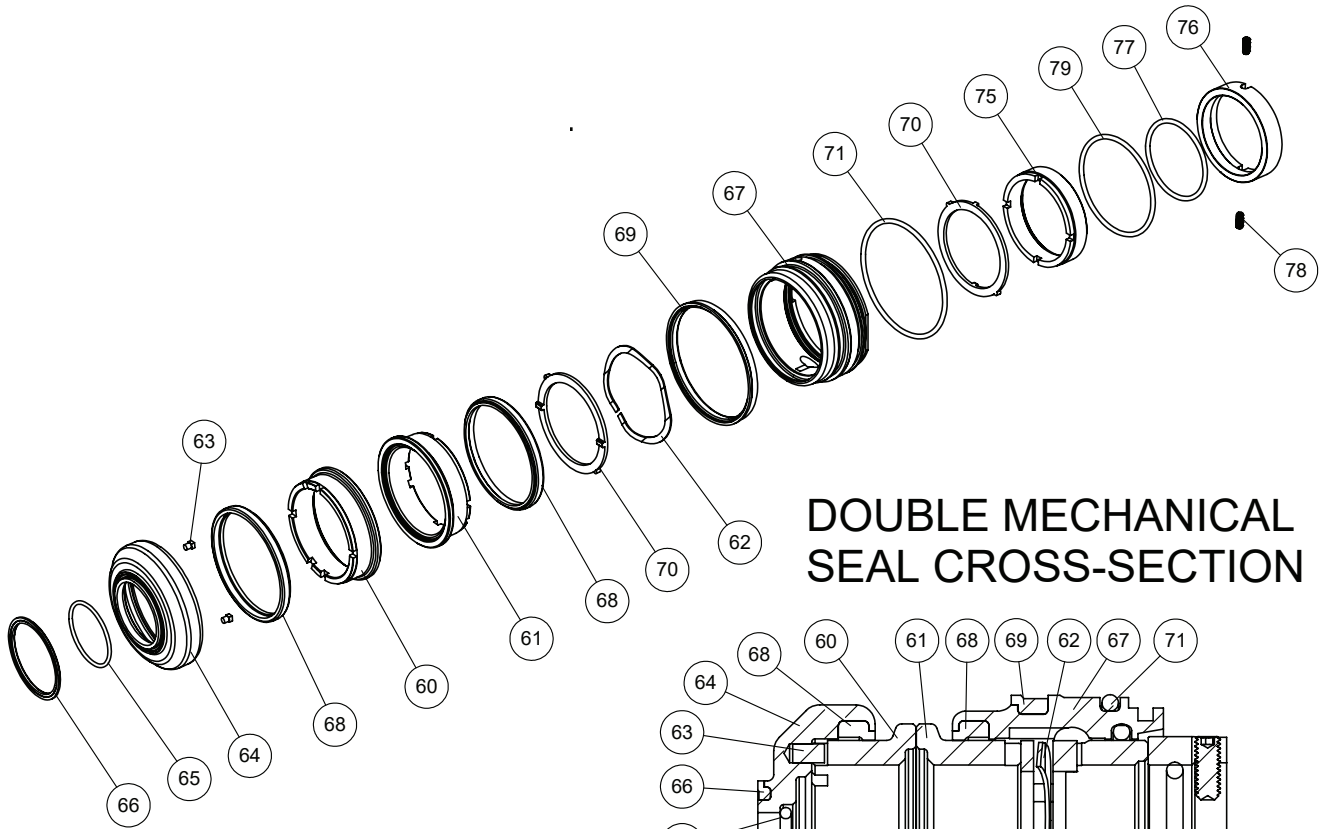

DOUBLE MECHANICAL SEAL CROSS-SECTION

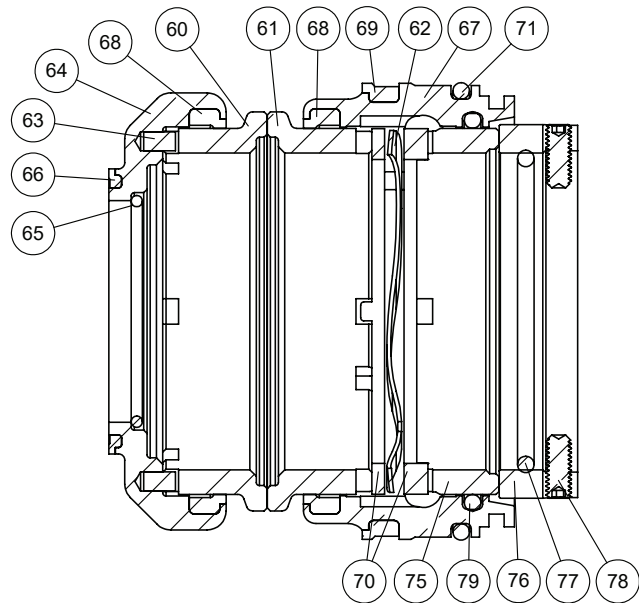

FCM Double Mechanical Seal		
Item	Qty	Description
60	1	Seal Face - Rotating
75	1	Outboard Stationary
76	1	Outboard Rotating
77	1	O-ring
61	1	Seal Face - Stationary
62	1	Wave Spring
78	2	Set Screw - Cup Point
63	2	Drive pin
64	1	Inboard Rotor Holder*
65	1	O-ring
66	1	Lip O-ring HFO
67	1	Inboard Flange*
68	2	Lip O-ring HRI
69	1	Lip O-ring HRO
70	2	Drive Disc*
71	1	O-ring
79	1	O-ring

*Complete Kit only

FCM Double Mechanical Seal Kits			
Model	Materials*		Wear Kit
	Stationary/Rotating/ Outboard Stationary/ Outboard Rotating/Elastomer	Complete Cartridge	
FCM 160	C/C/N/TC/V	1802601803	1802601804

* C = Silicon Carbide; N = Carbon; V = Viton; TC = Tungsten Carbide

MIXER DISASSEMBLY

REMOVE THE COVER, STATOR, AND CASING

- Before disassembly, adjust the stator to the maximum gap.
- Disconnect the flush water supply from the mixer.
- Disconnect the top flex push-to-connect flush water tube from the casing. It can remain attached to the housing.
- Remove the 4 long cover to housing nuts, washers, and bolts. The 8 short cover to casing bolts can remain in place.
- Remove the cover/stator/casing assembly from the housing. You may have to use a rubber mallet to gently tap the cover off the casing dowel pin.
- *Note: Please see the “Stator Disassembly” section if needed. It is not necessary when changing the seal.*

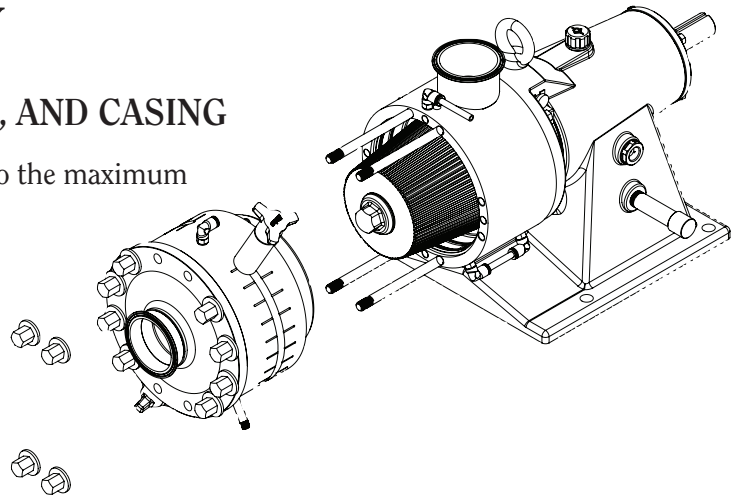

REMOVE THE ROTOR

- Place a chain wrench on the shaft to prevent it from rotating.
- Remove the rotor bolt.
- Inspect the rotor bolt gasket for damage.
- Remove the rotor by sliding it forward.

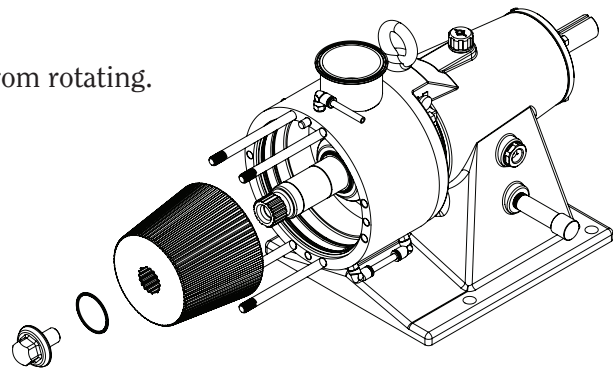

REMOVE THE ROTATING SEAL

- Remove the rotating seal from the shaft

REMOVE THE HOUSING

- Loosen the flange bolts.
- Remove the housing from the flange. You may have to use a rubber mallet to gently tap the housing. Be careful not to let the housing drop down onto the seal when sliding it off the flange.
- Inspect the 2 exposed stator O-rings for damage.

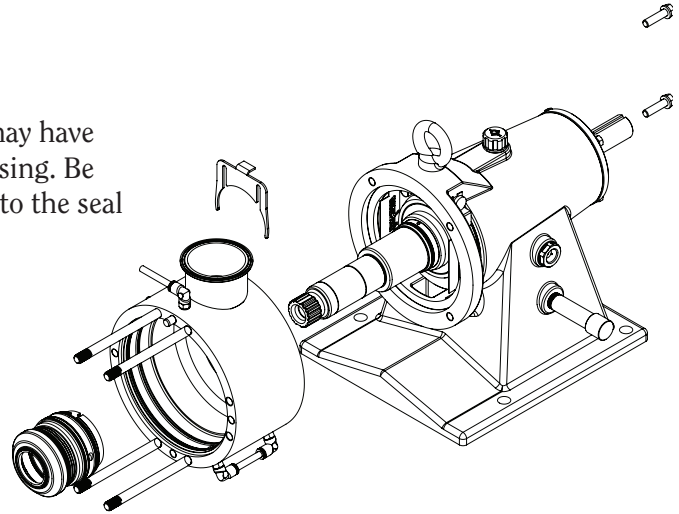

SEAL REPLACEMENT

MECHANICAL SEAL REMOVAL

- Place the housing seal side up on an even surface.
- Loosen the 2 seal retainer bolts
- Remove the seal retainer.
- Remove the flush seal from the shaft.
- Remove the stationary seal unit from the housing.
- Inspect as necessary.

MECHANICAL SEAL INSTALLATION

- Install the flush seal onto the shaft. Align the notches in the seal to the installed set screws.
- Lubricate the outer O-ring of the stationary seal.
- Line up the notch to the outside of the housing.
- Install the mechanical seal retainer. Ensure that it is fully engaged with the notch of the stationary seal.
- Secure the seal retainer bolts.

MIXER ASSEMBLY



HOUSING INSTALLATION

- Slide the housing over the shaft until it meets the flange. Be careful not to damage the seal.
- Install the flange bolts and tighten to the proper torque.
- Install the rotating seal onto the shaft.

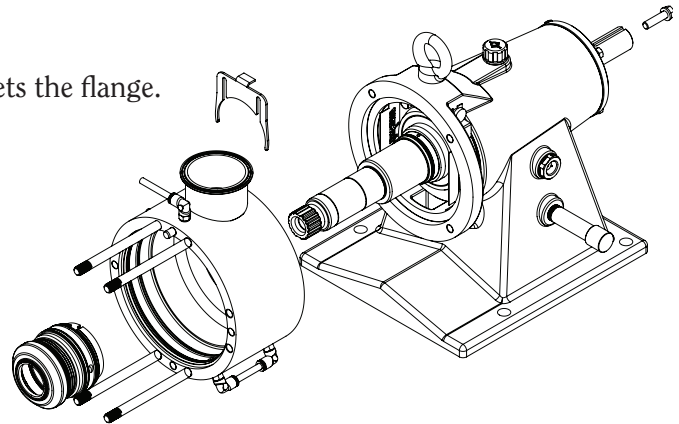

ROTATING SEAL INSTALLATION

- Install the rotating seal onto the shaft.

ROTOR INSTALLATION

- Slide the rotor onto the shaft.
- Place a chain wrench on the shaft to prevent it from rotating.
- Install the rotor bolt and tighten to the proper torque.

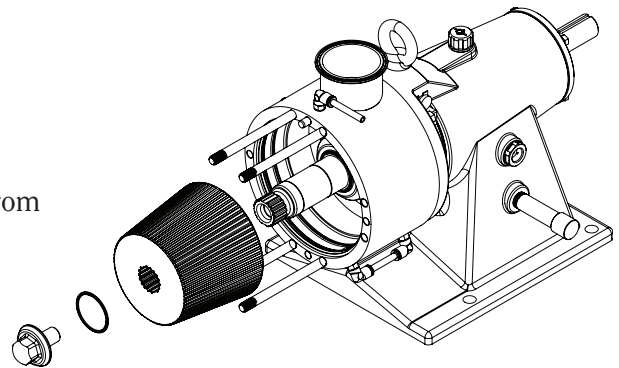

COVER, STATOR, AND CASING INSTALLATION

- Align the cover/stator/casing assembly with the 4 long housing studs.
- Slide the cover/stator/casing assembly over the rotor and onto the housing.
- Install the 4 sets of washers/nuts onto the long cover to housing bolts. Tighten the cover nuts to the proper torque in an equal pattern.
- Connect the top flex push-to-connect flush water tube to the casing.
- Connect the flush water supply to the mixer.

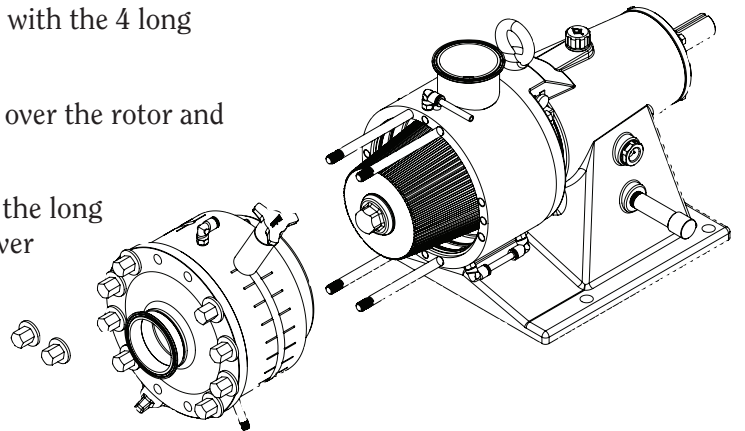

STATOR DISASSEMBLY (OPTIONAL, AS NEEDED)

- Remove the gap adjustment threaded studs without marring their outside diameters.
- Remove the other 8 cover nuts and washers.
- Remove the cover from the casing.
- Inspect the cover gasket for damage.
- Push the stator out of the casing through the front (cover side).
- Inspect the 2 stator O-rings for damage.

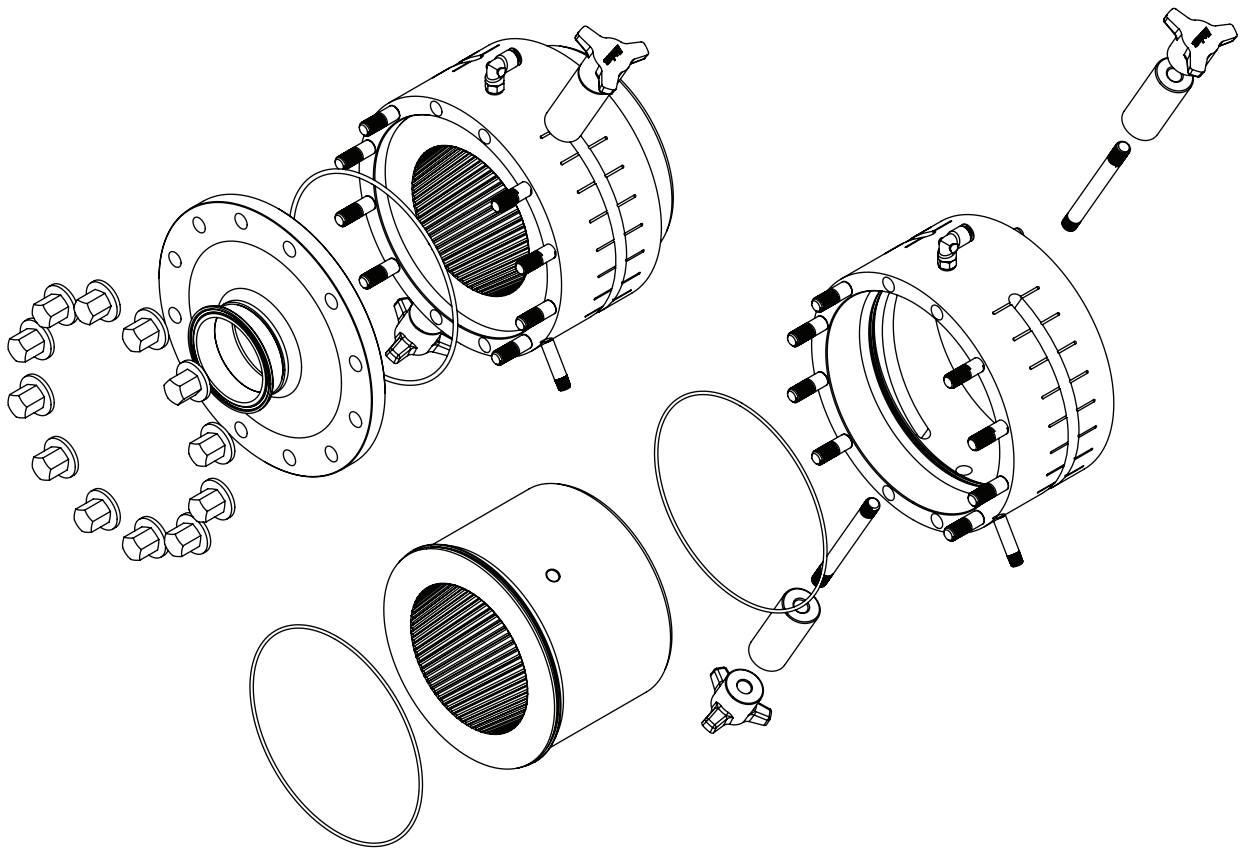

STATOR ASSEMBLY

- Install 3 buffer fluid O-rings into housing and casing, and 1 into the stator groove. **LUBRICATE LIBERALLY.** Rolling or pinching an O-ring will cause issues with gap adjustment.
- Install the stator into the casing. Align the threaded holes to the slots in the casing.
- Install the gap adjustment threaded studs without marring their outside diameters.
- Install the cover onto the casing.
- Install the cover bolts and washers and nuts. Tighten to cover nuts to the proper torque.
- Install the assembly onto the housing.

2VR BEARING BLOCK DISASSEMBLY

- Prior to disassembling the bearing block, complete the mixer head disassembly (as shown previously).
- Place an oil pan below the drain plug. Remove the drain plug cap and drain the oil. Replace the drain plug.
- Remove the front and rear bearing covers.
- Remove and discard the o-rings.
- Remove the snap ring.
- Tap on the splined end of the shaft with a soft-faced hammer to remove the shaft assembly. Support the shaft during removal so that it doesn't become damaged.
- Remove the outer race of the front bearing.
- Straighten the bent bearing lockwasher tab and remove the bearing locknut and washer.
- Remove the three rear bearings.
- Remove the snap ring.
- Remove the inner race of the front bearing by heating until it can be slid off.

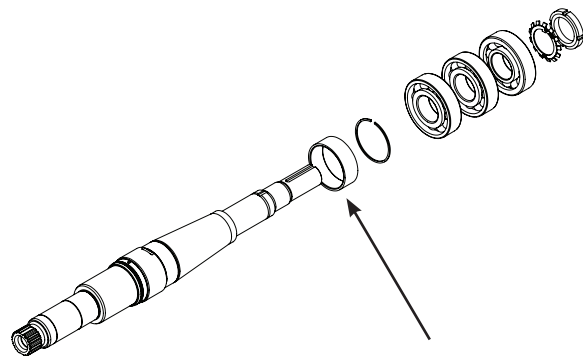
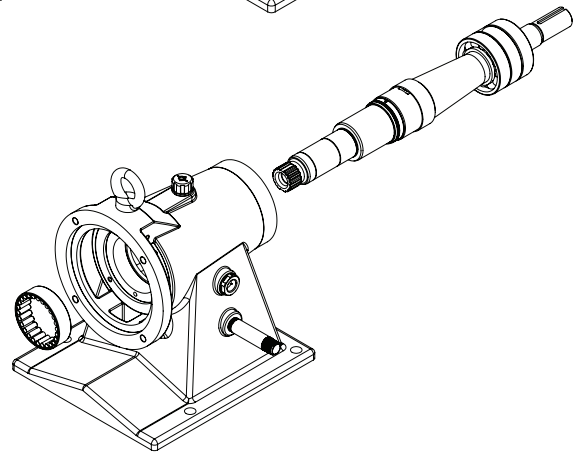
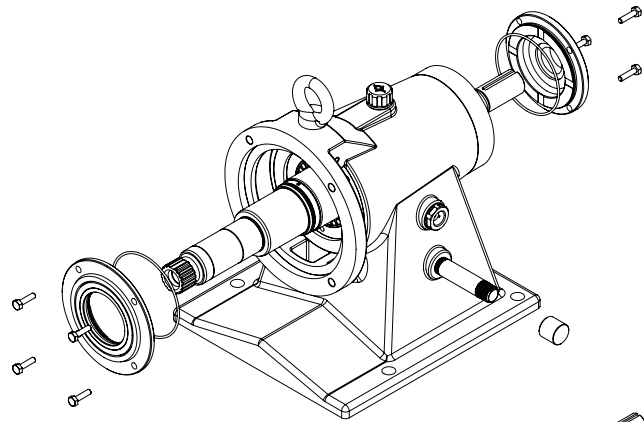

Front bearing inner race

2VR BEARING BLOCK ASSEMBLY

- Lightly grease the front bearing journal. Heat the front bearing inner race on a bearing heater to 230°F. Heating the bearing above 250°F will cause damage.
- Install snap ring to secure the front bearing race.

DISCLAIMER: Fristam greases bearing journals with Loctite® LB 8012. This grease contains graphite that will wash off during operation and can cause the oil to develop a gray color. This **DOES NOT** affect oil performance.

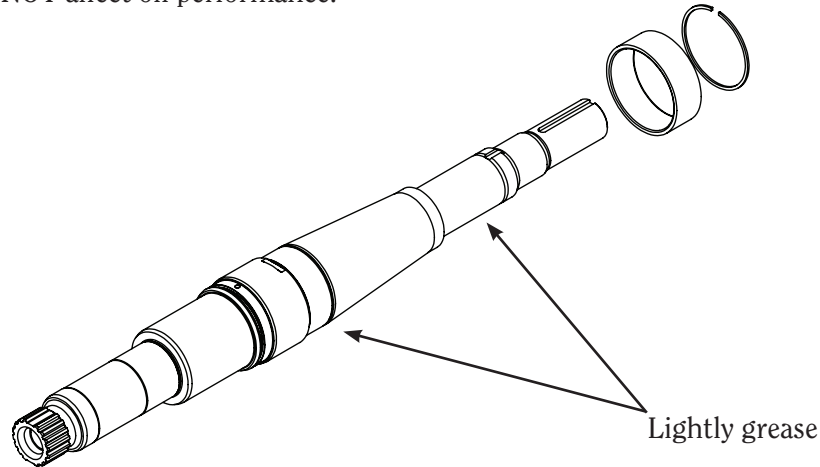

- Lightly grease the rear bearing journal. Heat the inner races of the rear bearings on a bearing heater to 230°F.
- Based on mixer's inlet, the middle bearing installation changes. See figure below.
- Install the bearing lockwasher and thread locknut until tight. Bend one of the lockwasher tabs into a slot on the locknut.

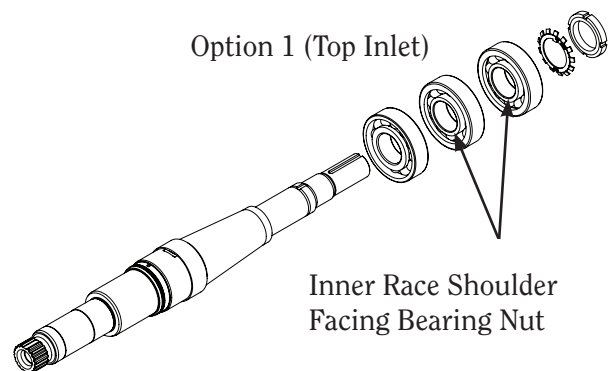
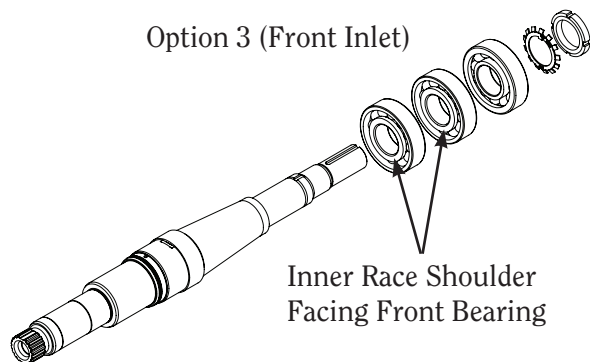

- Press the outer race of the front bearing into the bearing block.
- Install the shaft assembly into the rear of the bearing block. Press or tap on the outer race of the rear bearing while supporting the front end of the shaft. Do not press on the shaft or on the inner race of the rear bearing.

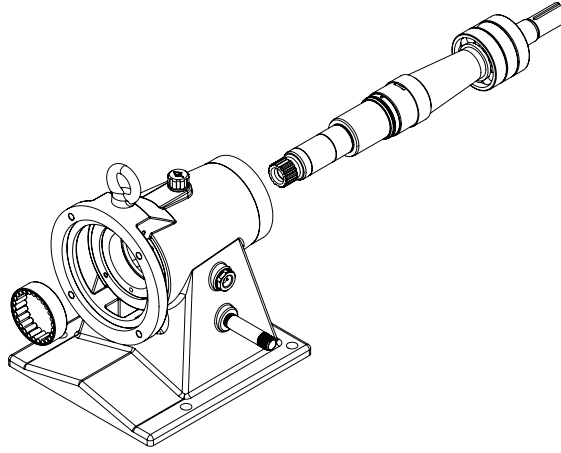

- To replace the labyrinth seals in the front or rear bearing covers: Press the seals out of the covers. Lubricate the new seals' outer diameters and o-rings. Press the new seals into the bearing covers with the drain holes in the downward position. Lubricate the inner diameters and o-rings on the seals.
- Install the front and rear bearing covers ensuring the seal drains are down. Use a torque wrench to tighten the bolts.
- Reinstall oil drain cap. Fill the bearing block with oil to the center of the sight glass and replace the vent cap.

NOTICE OF TERMS, WARRANTY PROVISIONS INCLUDING DISCLAIMERS, CLAIMS AND LIMITATION OF LIABILITY

Prices and all terms and conditions of sale are established in current price sheets and are subject to change without notice. All orders are subject to acceptance by Fristam Pumps USA Limited Partnership.

Each Fristam Pumps item is warranted to be free from manufacturing defects for a period of one (1) year from the date of shipment, providing it has been used as recommended and in accordance with recognized piping practice, and providing it has not been worn out due to severe service, such as encountered under extremely corrosive or abrasive conditions.

THIS WARRANTY IS EXPRESSLY IN LIEU OF ANY OTHER WARRANTIES EXPRESSED OR IMPLIED, INCLUDING BUT NOT LIMITED TO, ANY IMPLIED WARRANTY OF MERCHANTABILITY OR FITNESS FOR PARTICULAR PURPOSE. ALL OTHER WARRANTIES WHATSOEVER, EXPRESSED OR IMPLIED BY LAW OR OTHERWISE, ARE HEREBY EXCLUDED.

All claims must be in writing and mailed or delivered by purchaser within thirty (30) days after purchaser learns the facts upon which such claim is based. Any claim not made in writing and within the time period specified above shall be deemed waived.

PURCHASER'S SOLE AND EXCLUSIVE REMEDY AND FRISTAM PUMP'S MAXIMUM LIABILITY FOR CLAIMS ARISING HEREUNDER OR FOR NEGLIGENCE FOR ANY AND ALL LOSSES AND DAMAGES RESULTING FROM ANY CAUSE SHALL BE EITHER THE REPAIR OR REPLACEMENT OF DEFECTIVE ITEMS OR, AT FRISTAM PUMPS' OPTION, THE REFUND OF THE PURCHASE PRICE FOR SUCH ITEMS. IN NO EVENT, INCLUDING IN THE CASE OF A CLAIM FOR NEGLIGENCE, SHALL FRISTAM PUMPS BE LIABLE FOR INCIDENTAL OR CONSEQUENTIAL DAMAGES, INCLUDING LOSS OF PROFITS.

No person, including any representative, employee or agent of Fristam Pumps is authorized to assume on behalf of Fristam Pumps, any liability or responsibility in addition to or different from that described in this provision. Any and all representations, promises, warranties or statements that are in addition to or different from the terms of this provision are of no force or effect.

If any provision of this Notice is held to be invalid, such provision shall be severed and the remaining provisions shall continue to be in force.

END-OF-LIFE DISPOSAL

At the end of its life, our products should be recycled according to local guidelines

